

HVU HOSE REEL FOR HIGH VACUUM



TECHNICAL SPECIFICATION

Model	Description	Dimensions (mm)
74-050	Hose reel 10m, Ø32mm with antistatic hose	800 x 240 x 650
74-051	Hose reel 9m, Ø38mm with antistatic hose	800 x 240 x 650
74-052	Hose reel 7m, Ø50mm with antistatic hose	850 x 300 x 700

Weight (kg)	Brackets (mm)	Hose Ø (mm)	Hose Length (m)	Connecting to Channel (mm)
12	300 x 40	32	10	50
12	300 x 40	38	9	50
13	300 x 40	50	7	50

DESCRIPTION

The HVU hose reel is a robust and easy to use hose reel for use in high vacuum systems.

The hose reel has a number of characteristics that make it practical and user-friendly.

After use, the hose is automatically rolled back onto the hose reel, saving time and hassle in handling it.

The hose stop is easy to adjust and allows the user to select the optimum length of hose based on the individual task.

The hose reel has a micro switch fitted, so that the pressure in the hose is automatically activated when the hose is unrolled.

The hose reel is designed for easy installation. It is made of painted steel and the hose is anti-static and made of polyethylene and elastomer.

DIMENSIONS

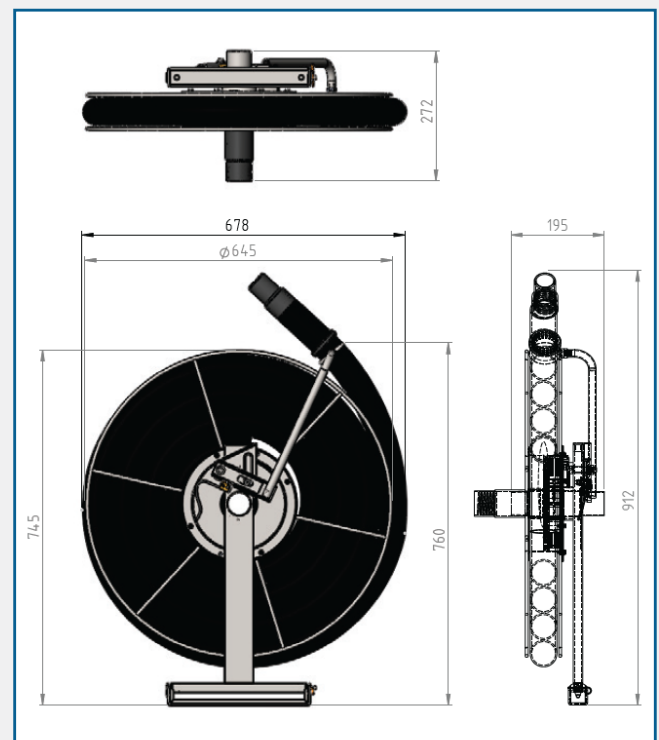

AES OFFER INSTALLATION AND SERVICE SUPPORT FOR ALL EQUIPMENT