

NEDERMAN HOSE REEL 884 FOOD GRADE



DESCRIPTION

Nederman 884 Food Grade Hose Reel is a heavy duty hose reel suitable for long and heavy hoses. Made of epoxy coated die cast aluminium. Ball bearings in drum and swivel.

Ideal for heavy industrial applications in which oil is required at hand, such as in the servicing of machinery or vehicles. The hose locks into place when the user pulls it to the desired length, the hose is then retracted by tugging the hose, releasing it from its locked state.

FEATURES

- Fully protected inner mechanisms
- Strong, durable and highly corrosion resistant
- Adjustable outlet arm minimises friction
- Easy service and cleaning

DIMENSIONS

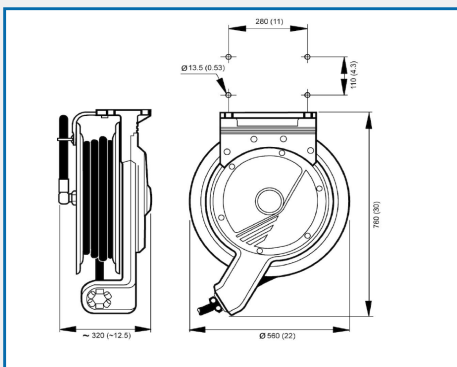

TECHNICAL SPECIFICATION

Product Name	Hose Reel 884
Material recycling	100 %
Connection hose length	1 m
Colour	Space blue/Blue
Weight	31,5 kg
Corrosion resistance	(Standard)
Electric/Spring driven	(Spring)

HOSE SPECIFICATIONS

Type of hose	Media	Delivered with hose	Distribution hose length (m)	Diameter, connection hose (mm)	Distribution hose diameter (mm)	Max working pressure (Mpa)	Part Code
E	Water, Food	Yes	10 m	25 mm	25 mm	2 Mpa	30861684
E	Water, Food		15 m	19 mm	19 mm	2 Mpa	30861784
E	Water, Food	Yes	20 m	12.5 mm	12.5 mm	2 Mpa	30861884

Hose type	Specification	Temperature range, °C	Hose fitting on free hose end, inlet hose	Hose connection on reel, distribution hose	Hose connection on reel, inlet hose
E	Cover in NBR/PVC and inner tube in food grade quality NBR. Single steel braid.	-40 - 155	Female 60° cone, chrome plated	Male 60° cone	Male 60° cone

AES OFFER INSTALLATION AND SERVICE SUPPORT FOR ALL EQUIPMENT