

## NEDERMAN H20 HOSE REEL - BLUE/GREY

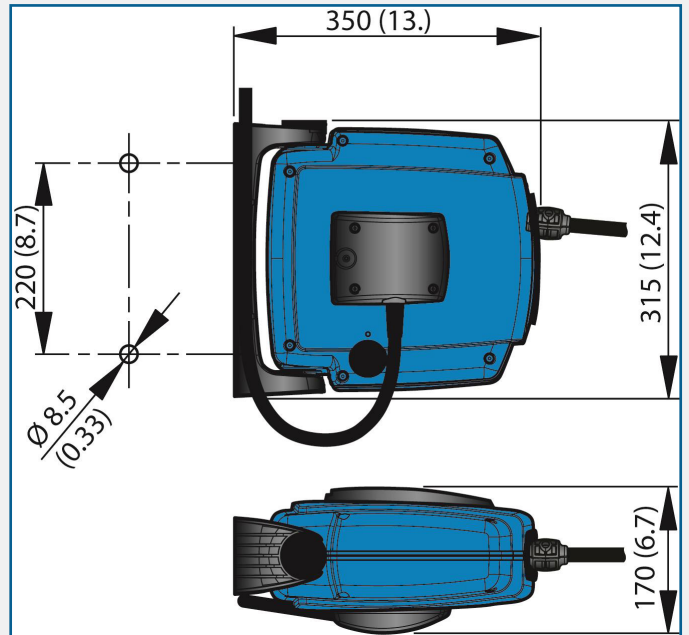

### DIMENSIONS



### DESCRIPTION

The Nederman retractable hose reel H20 for water and air is suitable for light industrial use, professional tradesmen or do-it-yourself workshops. The hose reel H20 is retractable and has a robust design in high impact composite materials. Supplied with an easily mounted snap-on, pivoting wall bracket and a unique safety latch for safe and easy service. The hose reel is equally suitable for pneumatic tools, staplers and blow guns.

The hose reel H20 is retractable and has an optimized spring force, ensuring that the hose retracts smoothly and evenly onto the drum. The high quality spring is pre-tensioned at the factory to suit a wide range of applications, and is well protected inside the drum cavity. The self retracting hose reel H20 is very easy to mount, either on walls or on ceilings.

### FEATURES

- Snap-on wall brackets
- Drum with ball bearings on both sides
- Pressed fitting and steel spiral hose protector
- Unique safety latch
- Hose easily replaced



AES OFFER INSTALLATION AND SERVICE SUPPORT FOR ALL EQUIPMENT

## NEDERMAN H20 HOSE REEL - BLUE/GREY

### HOSE REELS

Media	Delivered With Hose	Distribution Hose Length (m)	Distrubution hose diameter (mm)	Model
Compressed Air/Water	Yes	12	6	30800220
Compressed Air/Water	Yes	8	8	30800420
Compressed Air/Water	Yes	8	8	30810420

### TECHNICAL SPECIFICATIONS

Connection hose length	1.5 m
Material	PVC/PUR
Material recycling	100 %
Diameter, connection hose	10 mm
Corrosion resistance	Standard
Delivered with hose	Yes
Electric/Spring driven	Spring
Media	Compressed Air, Water
Max. working pressure	1.2 Mpa
Type of hose	A
Weight	3 kg
Certifications	CE



AES OFFER INSTALLATION AND SERVICE SUPPORT FOR ALL EQUIPMENT