

BenchTop Extraction Arm FX2 50 Original

Efficient, low-noise, and flexible extraction arms. FX2 original is a robust and reliable all-round arm for general use where there's minimal risk of electrical discharge or chemical exposure.



BenchTop Extraction Arm FX2 50 Original

- ✓ Efficiently optimises the capture zone and removes contaminants at the source
- ✓ Low noise levels for a safe and quiet workspace
- ✓ Various lengths and mounting options for flexibility
- ✓ Adjustable height for ergonomic efficiency
- ✓ Adapts to business needs for optimal workspace











Nederman FX2 arms are made of lightweight anodized aluminium sections, with two or three adjustable, composite friction joints. Offering strength and durability combined with easy handling, they can be used in many types of environment. They are especially suitable for applications where small, flexible and easy-to-use arms are required.

A robust and reliable all-round arm for general applications where there is little risk of electrical discharges or attack by aggressive chemicals.













BenchTop Extraction Arm FX2 50 Original

Certifications	CE
Noise level (dB(A))	60 dB(A) at 110 m ³ /h
Installation	Indoor
Material	Tubes in anodized aluminium. Joints in PP plastic. Duct connectors in EPDM rubber. Minihood in PP plastic.
Fume temperature	max 158 °F (70°C)
Extraction arm diameter (mm)	50
Airflow (m ³ /h)	50-110
Category type	Original







Models

	Item no	Arm length (m)	Colour	Weight (kg)	Ventilation type	Mounting type
	70600144	0,7	Aluminum and white	1,7	Down, Up	Surface Edge, Ceiling, Wall, On top of horizontal surface
	70600244	0,7	Aluminum and white	2,7	Up	Ceiling, Wall
	70600344	0,7	Aluminum and white	1,2	Down, Up	Surface Edge, Ceiling, Wall, On top of horizontal surface
	70600444	1,1	Aluminum and white	2,3	Up	Surface Edge, Ceiling, Wall, On top of horizontal surface
	70600544	1,1	Aluminum and white	3,3	Up	Ceiling, Wall
	70600644	1,1	Aluminum and white	2,3	Down	Surface Edge, Floor, Wall, On top of horizontal surface
	70600744	1,1	Aluminum and white	1,8	Down	Bench Through
	70600844	1,5	Aluminum and white	2,6	Up	Surface Edge, Ceiling, Wall, On top of horizontal surface
	70600944	1,5	Aluminum and white	3,6	Up	Ceiling, Wall
	70601044	1,5	Aluminum and white	2,6	Down	Surface Edge, Floor, Wall, On top of horizontal surface
	70601144	1,5	Aluminum and white	2,1	Down	Bench Through

Accessories

	Accessory	Item no
	FX-Bracket kit-D50/75/100-L190	70501144
	FX2-Bracket kit-D50/75/100-L500 Complete mounting kit, with the classic bracket, 500mm (19.68 inch) extension profile and associated parts, for mounting FX2 50/75/100 arms on the ceiling. For PLUS (double) and single swivels.	70377042
	FX2-Wall Bracket kit-Flat-L190-White. Complete mounting kit, with flat wall bracket,190 mm (7.48 inch) extension profile and associated parts, for mounting FX2 50/75/100 arms with 250mm from the vertical centre line of the arm to the wall.	70377043
	FX2-Wall-P Bracket kit-D50/75/100-L190. Complete mounting kit for mounting FX2 50/75/100 plus arms with 250 mm (9,84 inch) from the vertical centre line of the arm to the wall.	70377046
	FX2-Bench bracket kit-D50/75/100	70501444
	FX-Classic bracket-D50/75/100 (not for PLUS swivels)	70501244
	FX-Cut2fit extension-L1100	70501344
	FX-Cut2fit extension-L2200.	70374600
	FX-Ceiling cover plate	70502644
	FX2-Ceiling cover plate-PLUS	70377045
	FX-Combi hood-ORIGINAL-D50/75/100	70500144
	FX-Dome hood-ORIGINAL-D50/75/100	70376982
	FX-Metal hood-ORIG/CHEM-D50/75/100.	70500444

Accessories

	Accessory	Item no
	FX-Flange hood-ORIGINAL-D50/75/100	70502844
	FX2-Duct connector-ORIG/CHEM-D50.	70377036
	FX2-AI duct-L1000-D50 to D77. Aluminum duct with 77 mm (3 inch) diameter and 1000 mm (39.37 inch) length is designed to replace vertical ventilation duct above the swivel of FX2 50 arm. This is a good looking alternative to standard, ventilation duct.	70377056
	FX2-AI duct-L2000-D50 to D77. Aluminum duct with 77 mm (3 inch) diameter and 2000 mm (78.74 inch) length is designed to replace vertical ventilation duct above the swivel of FX2 50 arm. This is a good looking alternative to standard, ventilation duct.	70377057
	FX-Hose-D75-L3000-Grey Flexible hose in grey PVC with 75 mm (3 inch) diameter and 3000 mm (118.11 inch) length. It shall be used with hose support ring to connect hose to arm.	70377098
	FX2-Hose support ring-D75. Place into the 75 mm (3 inch) hose to support the connection between the hose and the duct connector of the arm.	70377067
	FX2-Cover small	70377452

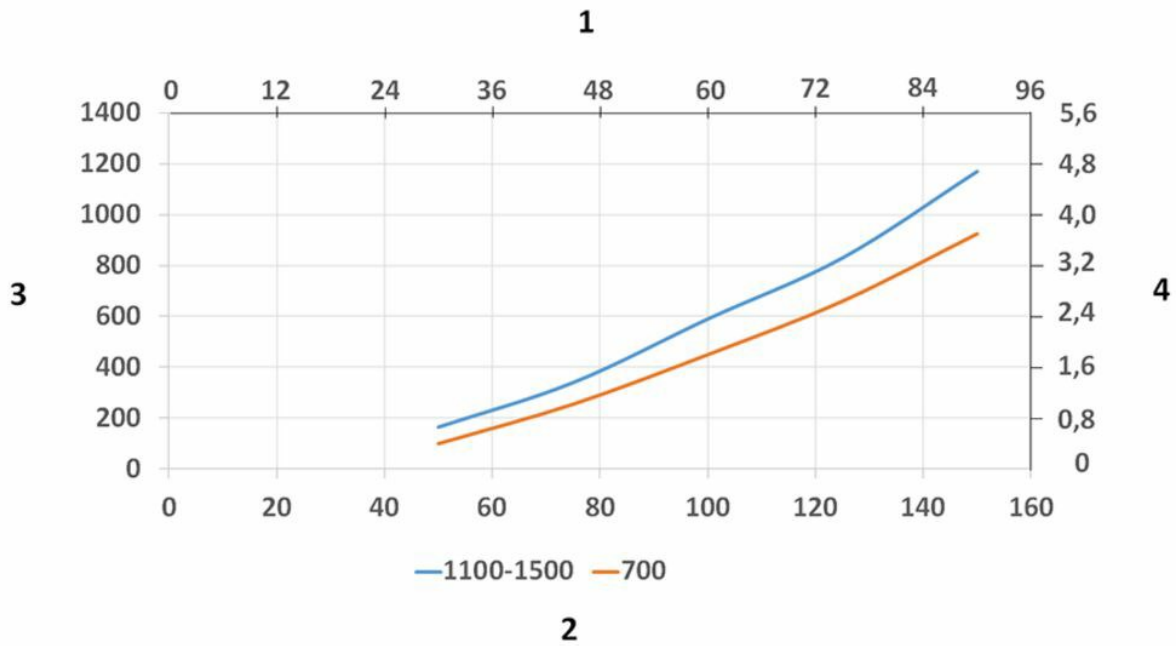

Pressure Drop diagram: 1) X- Axis: Air Flow Rate (cfm) 2) X- Axis: Air Flow Rate (m³/h) 3) Y-Axis: Static Pressure Drop (Pa) 4) Y-Axis: Static Pressure Drop (in. wg.)

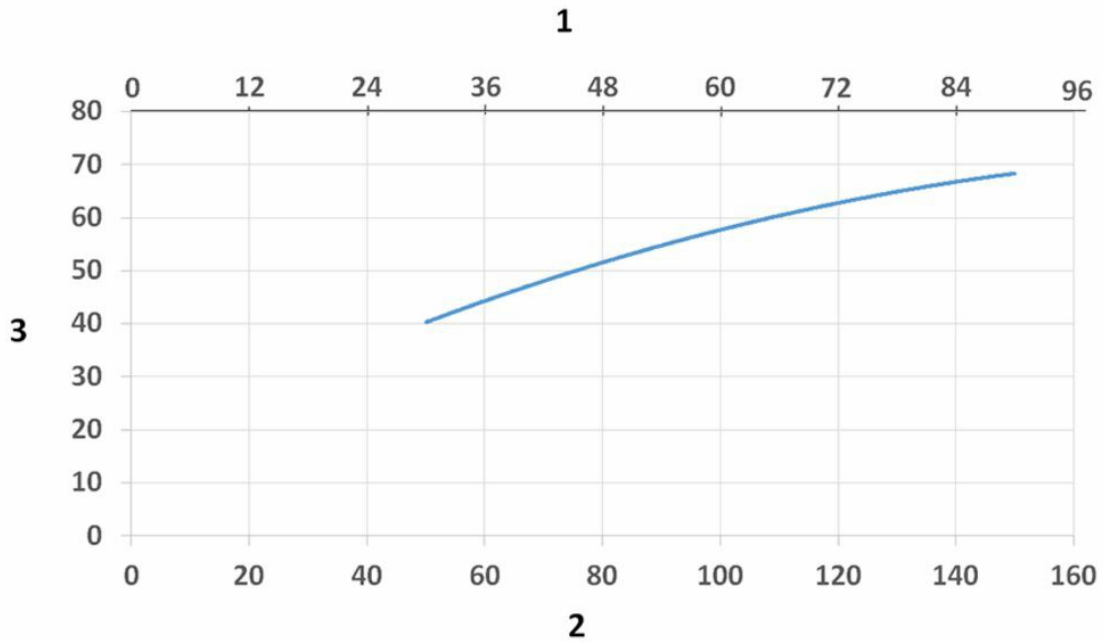

Sound Level diagram: 1) X- Axis: Air Flow Rate (cfm) 2) X- Axis: Air Flow Rate (m³/h) 3) Y-Axis: Sound Pressure Level (dB) (A)

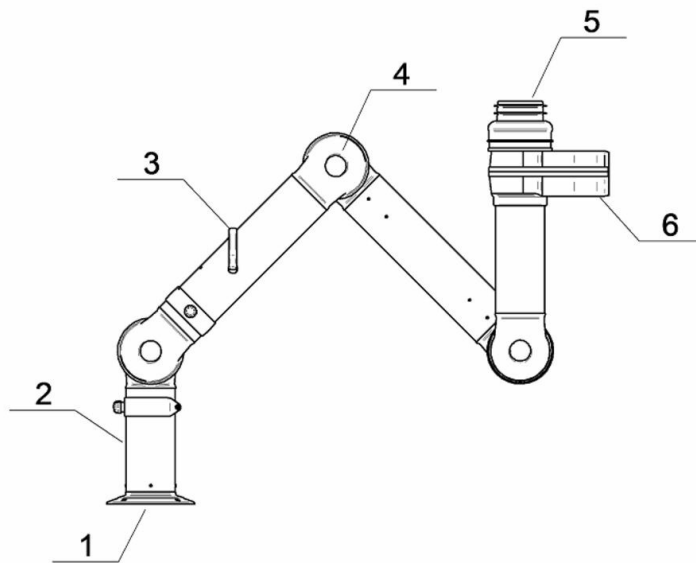

Material: 1) Flange: PP 2) Tubes: Aluminum, anodized 10 µm 3) Damper adjustment handle: Aluminum, anodized 10 µm Internal spring: Stainless steel Damper blade: Conductive TP & PP plastic 4) Joints: PP with glass fibre reinforcement Plastic rings: PP with glass fibre reinforcement Axial locking rings: PP with glass fibre reinforcement Adjustment knobs: PA & EDS plastic Threaded shaft inside joints: Stainless Steel 5) Duct connector: EPDM Rubber 6) Swivel: Aluminum, powder coating Rivets: Aluminum Bearings swivel: PP plastic with glass fibre reinforcement

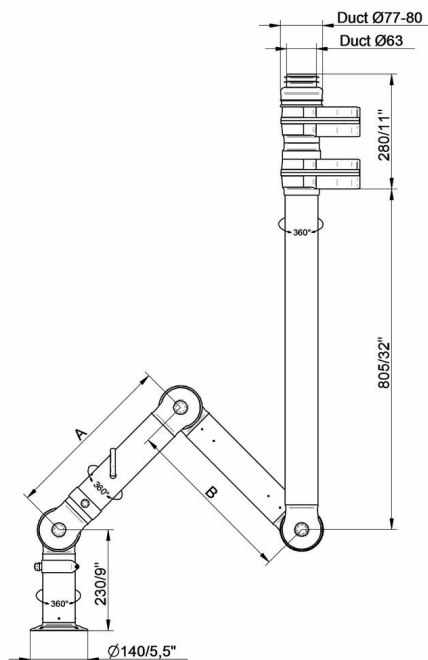

- FX2-ORIG-D50-L700-Up-PLUS Part number: 70600244 Max. working radius: 630 mm (24,8 inch) A: 400 mm (15,7 in) • FX2-ORIG-D50-L1100-Up-PLUS Part number: 70600544 Max. working radius: 1030 mm (40,5 in) A: 400 mm (15,75in) B: 400 mm (15,7 in) • FX2-ORIG-D50-L1500-Up-PLUS Part number: 70600944 Max. working radius: 1430 mm (56,3 in) A: 500 mm (19,7 in) B: 700 mm (27,6 in)

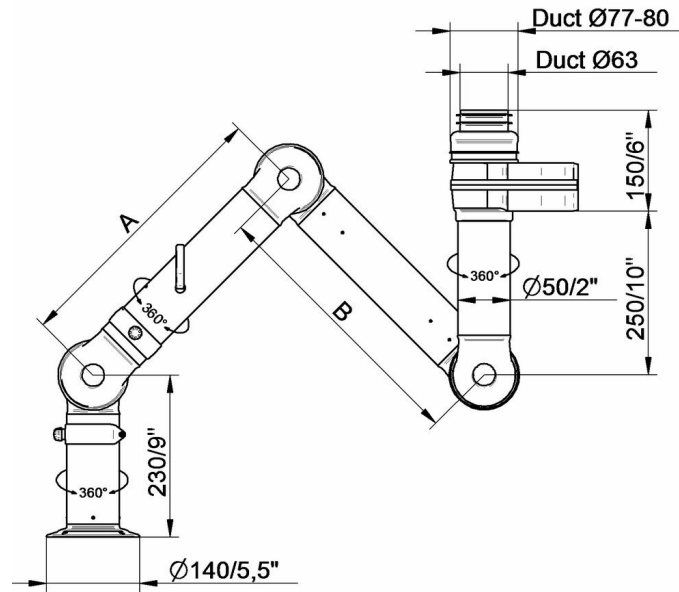

- FX2-ORIG-D50-L700-Up/Down-Low Part number: 70600144 Max. working radius: 630 mm (24,8 in) A: 400 mm (15,7 in)
- FX2-ORIG-D50-L1100-Up-Low Part number: 70600444 Max. working radius: 1030 mm (40,5 in) A: 400 mm (15,7 in) B: 400 mm (15,7 in)
- FX2-ORIG-D50-L1500-Up-Low Part number: 70600844 Max. working radius: 1430 mm (56,3 in) A: 500 mm (19,7 in) B: 700 mm (27,6 in)

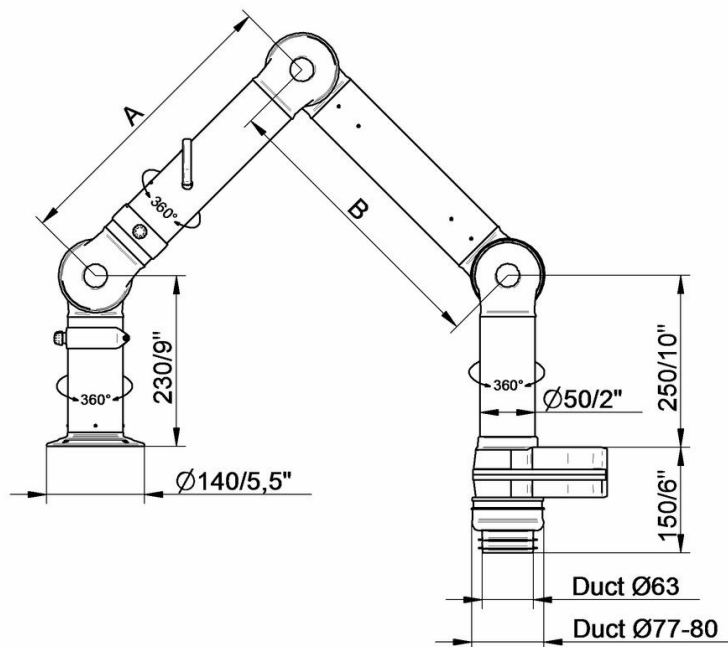

- FX2-ORIG-D50-L700-Up/Down-Low Part number: 70600144 Max. working radius: 630 mm (24,8 in) A: 400 mm (15,7 in)
- FX2-ORIG-D50-L1100-Down-Low Part number: 70600644 Max. working radius: 1030 mm (40,5 in) A: 400 mm (15,7 in) B: 400 mm (15,7 in)
- FX2-ORIG-D50-L1500-Down-Low Part number: 70601044 Max. working radius: 1430 mm (56,3 in) A: 500 mm (19,7 in) B: 700 mm (27,6 in)

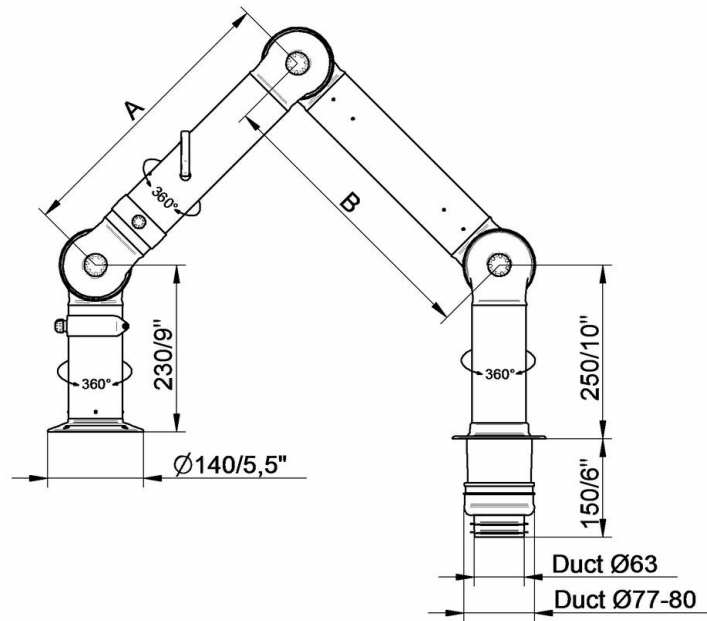

Part number: 70600344 Max. working radius: 630 mm (24,8 in) A: 400 mm (15,7 in) • FX2-ORIG-D50-L1100-Down-Through
 Part number: 70600744 Max. working radius: 1030 mm (40,5 in) A: 400 mm (15,7 in) B: 400 mm (15,7 in) • FX2-ORIG-D50-L1500-Down-Through
 Part number: 70601144 Max. working radius: 1430 mm (56,3 in) A: 500 mm (19,7 in) B: 700 mm (27,6 in)

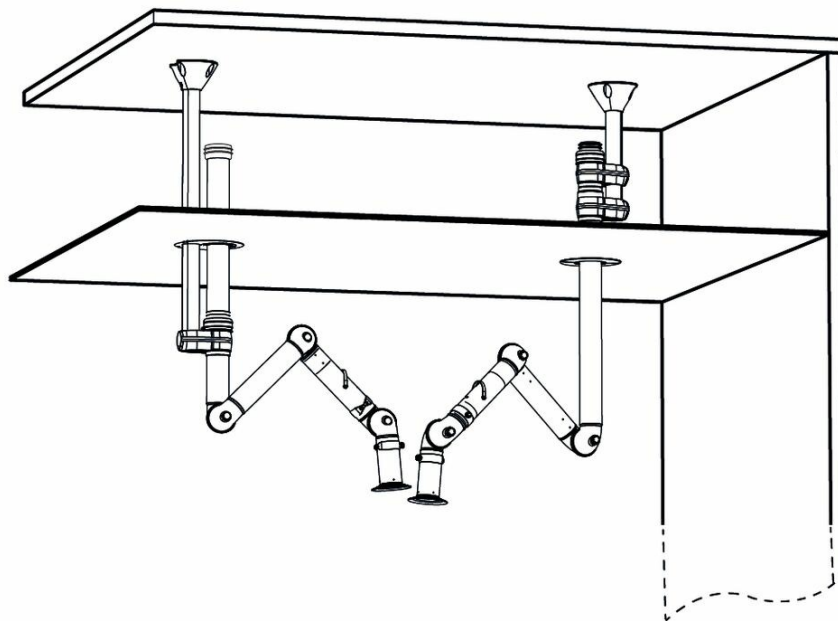

Ceiling mounting example: Left: FX2-Up-Low arm with following accessories: -FX-Classic bracket -FX-Cut2fit extension-L1100 -FX2-Alu duct -FX2-Duct connector-ORIG/CHEM-D75 -FX-Ceiling cover plate Right: FX2-Up-PLUS arm with following accessories: -FX2-Bracket kit-D50/75/100-L500 -FX2-Ceiling cover plate-PLUS

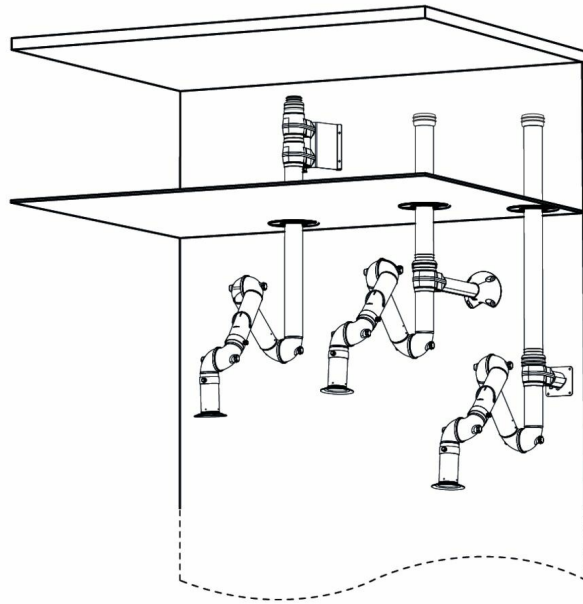

Wall mounting examples: Left: FX2-Up-PLUS arm with following accessories: -FX2-Wall-P BRKT kit-D50/75/100-L190 -FX2-Ceiling cover plate-PLUS Middle: FX2-Up-Low arm with following accessories: -FX2-Bracket kit-D50/75/100-L500 -FX2-Ceiling cover plate-PLUS -FX2-Alu duct -FX2-Duct connector-ORIG/CHEM-D75 Right: Up-Low arm with following accessories: -FX2-Wall BRKT kit-Flat-L190-White -FX2-Ceiling cover plate-PLUS -FX2-Alu duct -FX2-Duct connector-ORIG/CHEM-D75

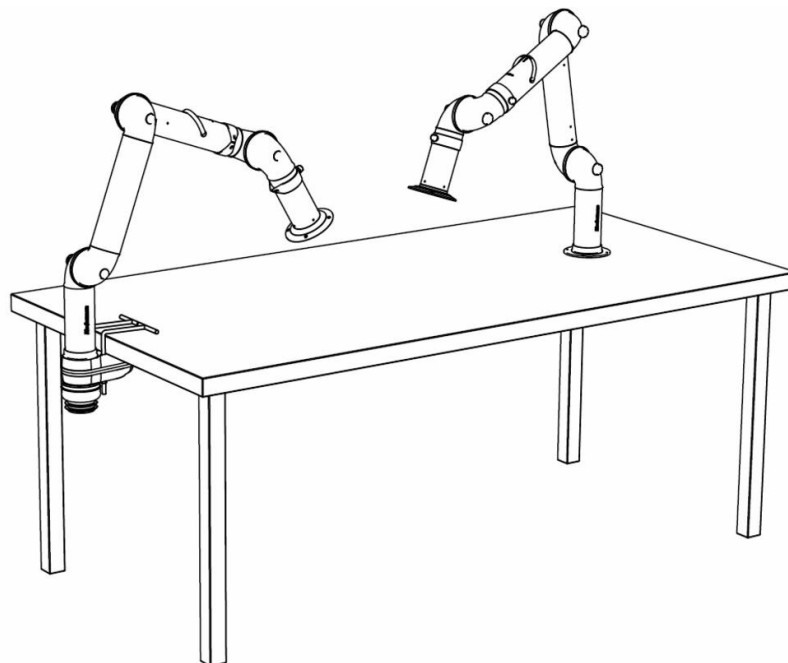

Bench mounting examples: Left: FX2-Down-Low arm with following accessories: -FX2-Bench bracket kit-D50/75/100 Right: FX2-Down-Through arm

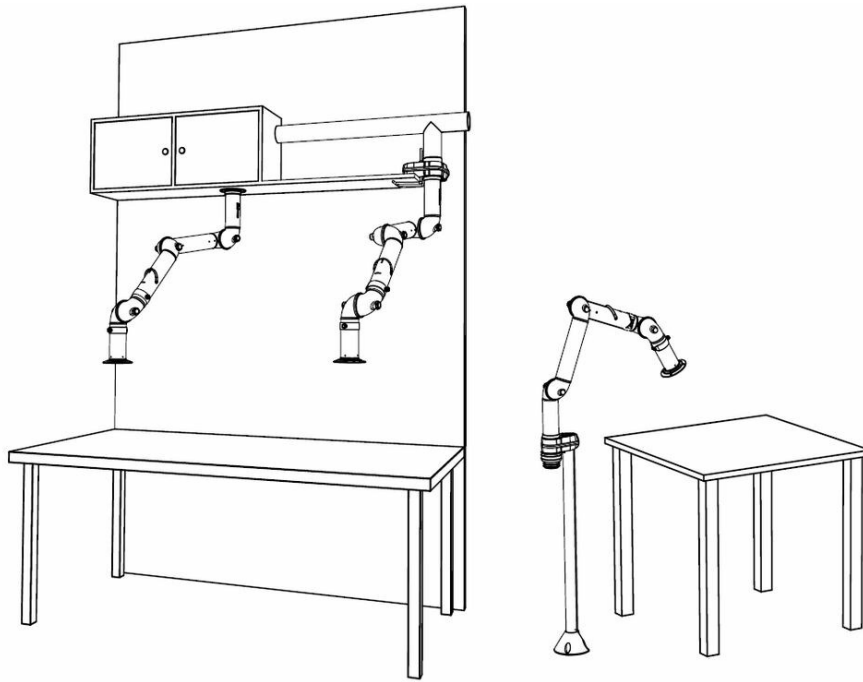

Other mounting examples: Left: Over bench cabinet mounting with FX2-Up/Down-Through arm Middle: Shelf mounting with FX2-Up-Low arm and following accessories: -FX2-Bench bracket kit Right: Floor mounting with FX2-Up-Low arm and following accessories: -FX-Classic bracket -FX-Cut2fit extension-L1100