

BADA - Certified ATEX non-return valve

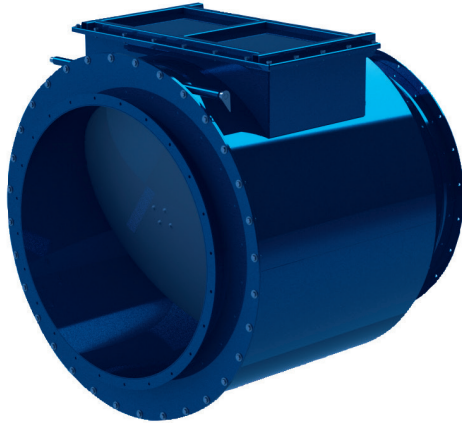

DESCRIPTION

An explosion involves not only the immediate processed material, but can also propagate to the rest of the process. This propagation can be avoided if the affected processed material is quickly isolated by a non-return valve.

The BADA non-return valve is designed to separate the filter from the plant. It is a simple and effective system that is easy to install, without electronics which requires no electrical connections, practically no maintenance and with very low pressure loss.

The BADA non-return valve is an excellent ATEX certified Safety system for the compartmentalization of an explosion and is suitable for use in Ex zone 21 (ext.) and up to Ex zone 20 (int.).

ADVANTAGES

- Economically suitable solution for security against an explosion
- Completely mechanical requiring practically no maintenance
- NO power consumption
- Low pressure losses
- High pressure resistance

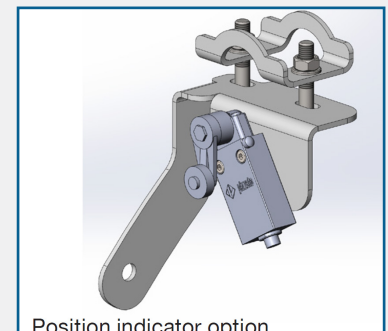
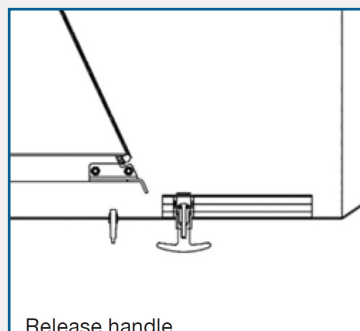
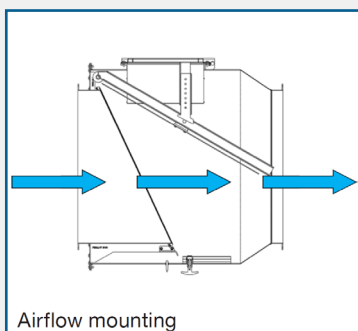

TECHNICAL SPECIFICATION

Material

Body : steel 16MO3 (EN 10028)
Closing flap : HB 400 HARDOX (EN10051) Surface treatment : powder coated RAL 5010

Type

Welded plates with welded FA flanges

Technical Information

- Series includes diameters Ø 200 up to Ø1000
- Conformity according to: EN 16447: 2014
NFPA 69 Regulations
- Certification Number: FTZU 18 ATEX 0141 X
FTZU 16 ATEX Q 002
- ATEX norm 114 : 2014/34/EC
- Exterior zone certification : 21-22
- Interior zone certification : 20-21-22
- Level of protection : St1 (organic & nonmetallic) up to 200 bar m/s
- Kst max. : 200 bar.m.s-1
- Pred,max. : 0,5 bar
- Maximum airspeed : 30 m/s
- Use : Indoors or outdoors
- Min. / Max installation distance from filter:
Ø200: 2m to 7m
Ø200 - 400: 3m to 7m
Ø450 - 1000: 4m to 7m
- Max. dust concentration in duct : 400 g;m-3
- Only to be used in horizontal ducting
- Temperature range : -20°C to +40°C.

OPTIONS

- Position indicator for BADA
- Dust level indicator for BADA

AES OFFER INSTALLATION AND SERVICE SUPPORT FOR ALL EQUIPMENT

BADA - Certified ATEX non-return valve

BADA MODEL DIMENSION SCHEMATIC

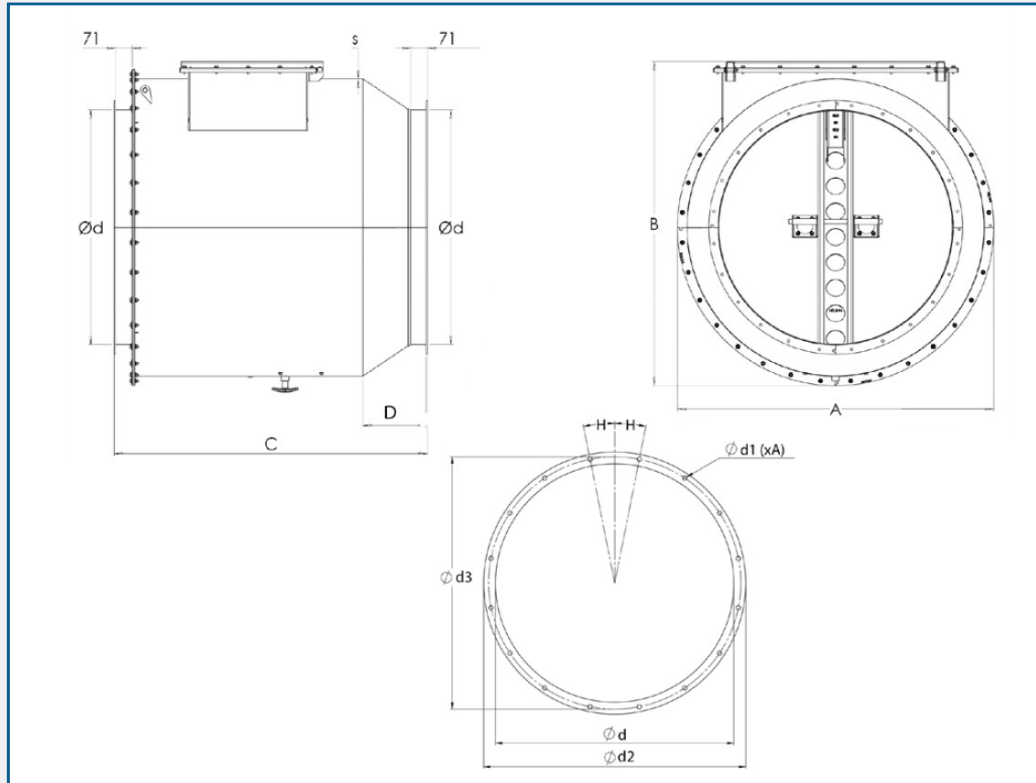

BADA MODEL DETAILS

Ød (mm)	Code	A (mm)	B (mm)	C (mm)	D (mm)	d1 (mm)	d2 (mm)	d3 (mm)	A qty	H (°)	S (mm)	Weight (kg)
200	BADA000018	470	510	590	137	10	255	235	12	15	3	45
250	BADA000019	520	555	620	137	10	305	285	12	15	3	52
300	BADA000020	570	610	640	137	10	355	336	12	15	3	60
350	BADA000021	620	660	670	137	12	415	389	12	15	3	70
400	BADA000022	670	710	735	157	12	465	439	16	11.25	3	83
450	BADA000023	720	760	785	157	12	515	489	16	11.25	3	94
500	BADA000024	770	810	835	157	12	565	540	16	11.25	3	106
550	BADA000025	820	860	885	157	12	615	590	16	11.25	3	118
600	BADA000026	870	910	935	157	12	665	640	16	11.25	3	130
650	BADA000010	985	1021	1090	247	12	715	690	24	7.5	3	169
700	BADA000011	1035	1072	1120	247	12	785	750	24	7.5	3	185
750	BADA000012	1085	1127	1150	247	12	835	800	24	7.5	3	199
800	BADA000013	1152	1213	1220	277	12	885	850	24	7.5	3	229
850	BADA000014	1202	1263	1340	277	12	935	900	24	7.5	3	241
900	BADA000015	1252	1313	1340	277	12	985	950	24	7.5	3	268
950	BADA000016	1302	1363	1340	277	12	1035	1000	24	7.5	3	281
1000	BADA000017	1352	1413	1340	277	12	1085	1050	24	7.5	3	294

AES OFFER INSTALLATION AND SERVICE SUPPORT FOR ALL EQUIPMENT