

AD 1000 Pro OS Connect

Fume Extraction System - Advantage Range

Datasheet

Technical Specification and Product Information

An extraction system for medium to heavy-duty laser applications.

The AD 1000 Pro OS Connect fume extraction system is an ideal choice for applications that generate high levels of particulate. Equipped with our new, innovative Pro OS software platform, this intuitive system takes productivity to the next level.

FEATURES

- Two-way data stream
- Color touch screen
- Real-time system status
- Multi-language software
- Customizable branding
- Filter life monitor
- Pressure sensors
- Alarm configurations
- USB lock screen

Approvals: UK and CE | cUL | UL*



TECHNICAL SPECIFICATION

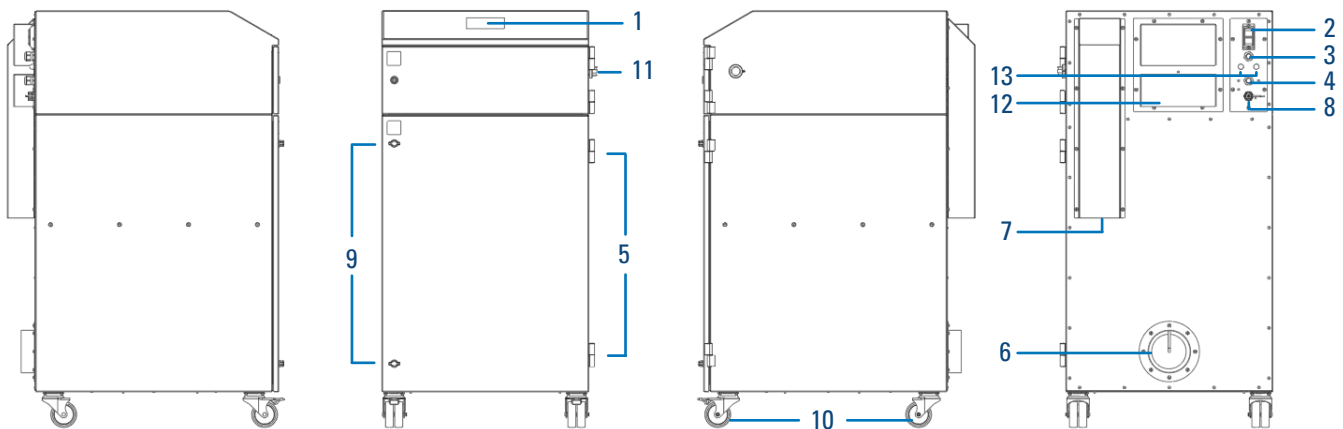

1. Touchscreen display
2. On/off switch
3. Power cable
4. Signal/interface cable
5. Door hinges
6. Hose inlet connection - 2.95" (75 mm)
7. Exhaust outlet
8. RJ45 ethernet port**
9. Door latches
10. Castors
11. USB port
12. Blower cooling outlet
13. Overcurrent trips (115 V only)

TECHNICAL DATA

Voltage	Unrestricted airflow*** (+/- 10%)		Settable airflow range****		Pressure (+/- 6%)	Dimensions (H x W x D)		Weight (+/- 5%)		Noise level*****	Frequency	Full load current
	V	cfm	m ³ /hr	cfm		m ³ /hr	in	mm	lbs			
115	515	875	177-430	300-730	65	47.4 x 24.6 x 31.7	1205 x 625 x 805	309	140	< 70	50/60	19.5
230			177-459	300-780	60							12.8

AIRFLOW

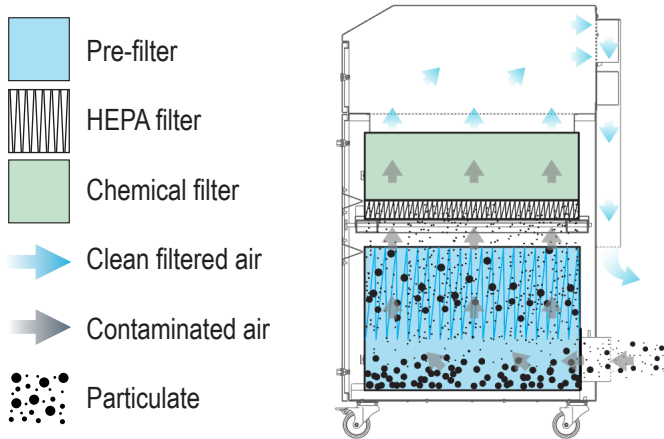

PART NUMBERS - SYSTEM

Description	Part number
Stainless steel, 230 V 24 V S/S, SOK, VOC, UK Plug	1U8700106705
Stainless steel, 230 V 24 V S/S, SOK, VOC, EU Plug	1U8705106705
Stainless steel, 115 V 24 V S/S, SOK, VOC, USA Plug	1U8710105705
Powder-coated, 230 V 24 V S/S, SOK, VOC, UK Plug	1U8700811705
Powder-coated, 230 V 24 V S/S, SOK, VOC, EU Plug	1U8705811705
Powder-coated, 115 V 24 V S/S, SOK, VOC, USA Plug	1U8710810705

FILTER SPECIFICATIONS

Model	Surface media area (approx)		Filter efficiency
	ft ²	m ²	
DeepPleat DUO pre-filter	322.8	30	ePM1 70%
Combined filter (HEPA)	80.7	7.5	99.995% @ 0.3 microns

Model	Activated carbon volume	
	ltr	
Combined filter (gas)	53.7	

PART NUMBERS - FILTERS

DeepPleat DUO pre-filter	Combined filter
1UA1030222	1UA1030297

Cabinet construction

Brushed stainless steel
Powder-coated mild steel (RAL7016)

Compatible accessories:

Spark Arrestor 2
ILF 600

*UL: Tested to UL standards, but testing may be provided by alternate nationally recognized test laboratories. Certain product configurations may affect the UL certification. Please speak to your sales representative.

**Connectivity: The Pro OS models feature connectivity via an RJ45 port which is located on the rear of the extraction system. This port can be used as 2-way communication, enabling the control of the extraction system as well as live data streaming from the system. For information on how to configure your device to communicate with the Pro OS, please use document: SG-PRO OS CONNECT PROTOCOL CONFIGURATION GUIDE-BOFA-US

*** Unrestricted airflow: The airflow values provided with clean filters, no hose kit, at 230 V, measured by using a wind vane. The numbers may vary depending on voltage and test procedure used.

**** Settable range: Donaldson BOFA recommends utilizing the lowest flow rate that achieves the correct capture velocity for your application in order to maximize filter life.

***** Noise level: At typical operating speed.

Datasheet correct at time of publishing. Where applicable, the carbon used in Donaldson BOFA systems is capable of removing a wide range of VOCs, however it is the responsibility of the user to ensure the carbon is suitable for their application. For specific applications, please contact us for details.

Important Notice

Many factors beyond the control of Donaldson can affect the use and performance of Donaldson products in a particular application, including the conditions under which the product is used. Since these factors are uniquely within the user's knowledge and control, it is essential the user evaluate the products to determine whether the product is fit for the particular purpose and suitable for the user's application. All products, product specifications, availability and data are subject to change without notice, and may vary by region or country.



FS 643451
ISO 9001

Approvals: REACH and RoHS.
See individual product technical data for specific accreditations.