

CSX CIRCULAR SAW EXTRACTOR



TECHNICAL SPECIFICATION

Dimensions (WxDxH)	1250 x 851 x 800 mm to 977 mm (can be made taller upon request)
Fan Motor	1.5 kW – 2 pole – 415/3/50 or 240/1/50
Filters	4 x Tubular Terylene Needle Felt
Filter Area	2.00 m ²
Filter Cleaning	Manual Agitation
Waste Collection	Dust Tray
Explosion Relief (optional)	Rear of extractor – Inlet area
Fan Inlet	1 x 80 mm & 1 x 150 mm

DESCRIPTION

The Mardon CSX Extractor has been designed specifically for use with circular saws. It is compact and comes complete with a wooden run off table allowing the extractor to replace the traditional free-standing run off table.

It has been well tried and tested over many years, during which time it has been constantly refined and improved.

FEATURES

- Compact.
- Comes with a wooden top which is height adjustable.
- Low cost filter replacements.
- Designed specifically for circular saw applications.
- Can be used in conjunction with the Mardon crown guard kit.
- Also available as an ATEX compliant version for use with hazardous materials.



CSX CIRCULAR SAW EXTRACTOR

DIMENSIONS

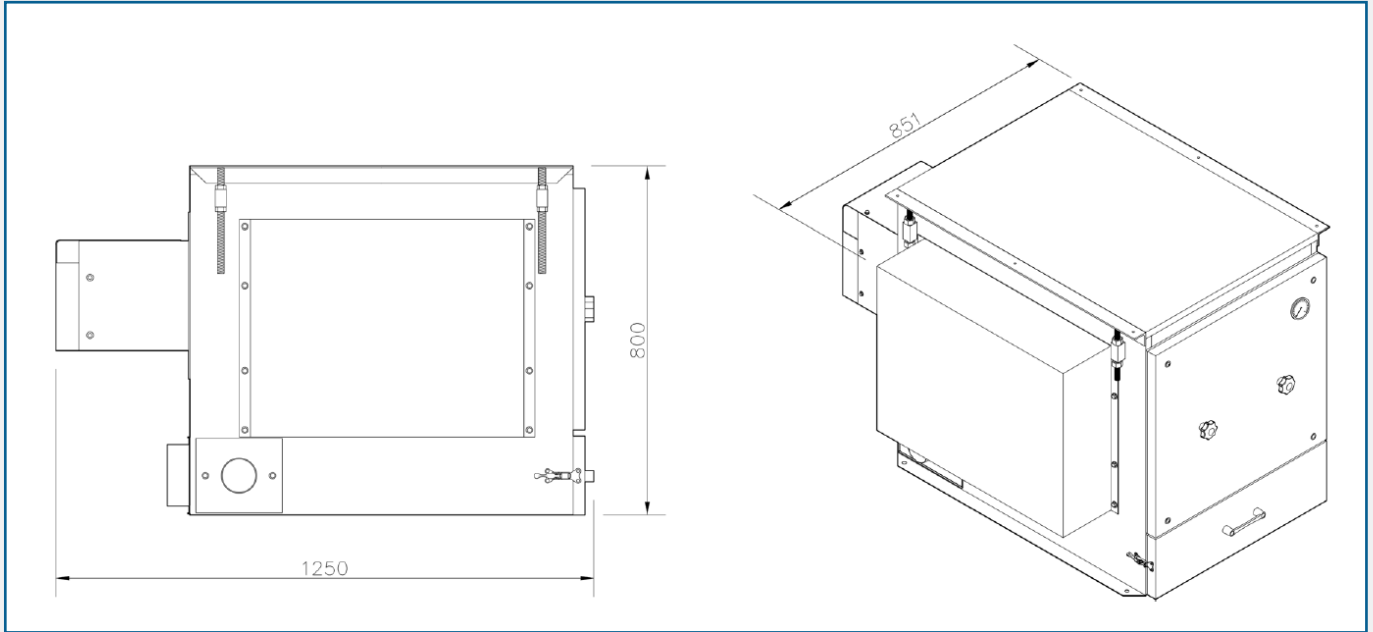

PERFORMANCE

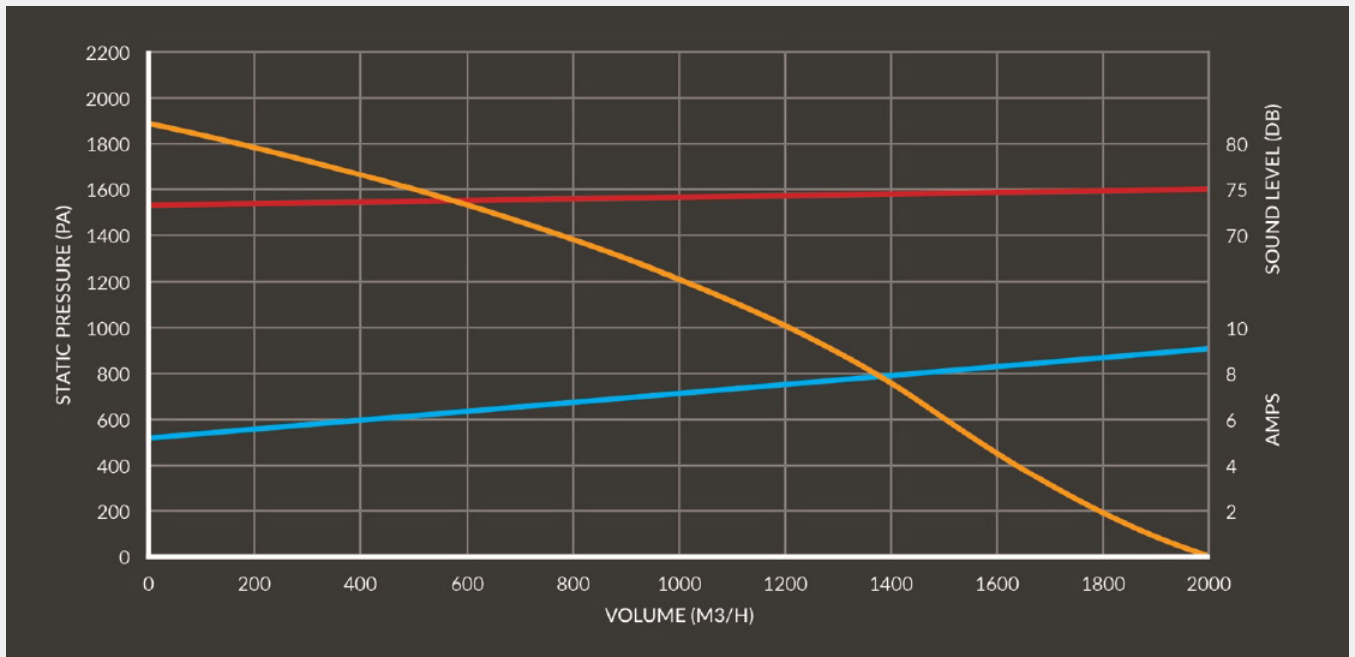

AES OFFER INSTALLATION AND SERVICE SUPPORT FOR ALL EQUIPMENT