

OSF 500 FC



TECHNICAL SPECIFICATION

Capacity (max airflow m3/h)	500
Certifications	CE
Filter cleaning method	Self-Draining
Filter efficiency (%)	99.95
Installation	Indoor
Material	Sheet metal, painted both in- and outside.
Operating Temperature	40 deg C (inbuilt fan)
Protection class	IP55
Standard	2009/125/EC
Volume (for shipping) (m3)	1.1
Working pressure (kPa)	Max 2500 Pa
Amperage (A)	3.46 / 2.0
Colour	NCS-S 1005 B20G
Frequency (Hz)	50
Number of filter elements	3
Noise level (dB(A))	65 dB(A) @1.5 m from service side
No of phases	3
Power (kW)	0.75
Power Voltage (V)	230/400
Weight (kg)	150

DESCRIPTION

Nederman OSF oil smoke eliminators are designed to handle large amounts of neat oil mist during continuous operation. They are developed with focus on high efficient filtration together with low maintenance cost.

Nederman OSF 500 FC has as standard 3 filter-stages where the first 2 stages consists of filter cassettes with Nederman's FibreDrain® technology. Nederman have a wide range of different types of filters to suit many different kind of applications. The third stage consists of a HEPA filter in filter class H13 with an efficiency of 99,95% for MPPS according to EN1822. OSF 500 FC have an built-in chamber fan.

FEATURES

- Three filter stages
- Gauges for reading of pressure drop over each filter stage
- Compact design
- Two inlet \varnothing 150 mm with clamp ring connection
- Starter and motor protection included

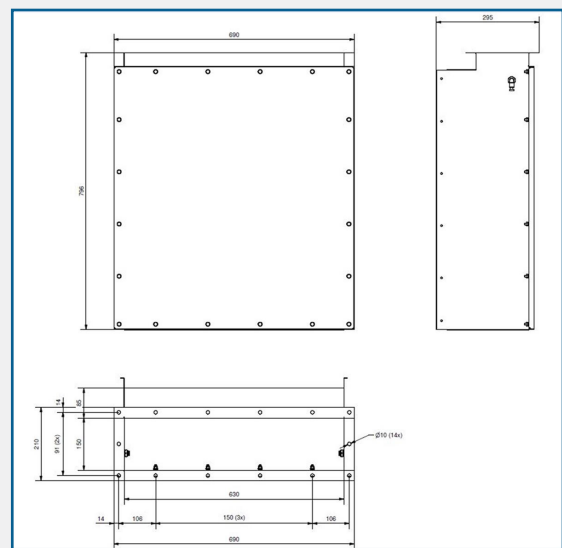
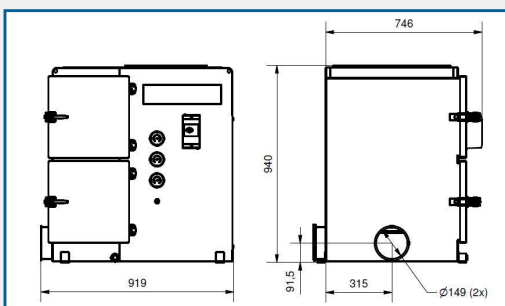

AES OFFER INSTALLATION AND SERVICE SUPPORT FOR ALL EQUIPMENT