

NEDERMAN FILTERBOX WALL

TECHNICAL SPECIFICATION

Compressed Air Requirement	DIN ISO 8573-1, class 5/5/4 (7 bar)
Extraction Arm Diameter	Ø160 mm
Electrical Plug	Without
Arm Length	Without
Number of Filter Elements	1
Max. Airflow	1300 m ³ /h
Collection Bin	15 litres
Frequency	50 Hz
Weight	54 kg
Installation	(Indoor)
Material	Casing in rotomoulded plastic
Filter Type	Cartridge
Filter Area	13 m ²
Filter Efficiency	99 %
Protection Class	IP 54
Sound Level	60 dB(A) (without fan) 66 dB(A) (N24 fan) 74 dB(A) (N25 fan)



DESCRIPTION

The Nederman FilterBox can come with or without a fan attached. The models without a fan are suitable for installations with an external fan and fan contactor, and can be used with multiple FilterBox units.

The unit is delivered with a wall bracket for easy installation. Depending on the model, the filter cartridge is either manually or automatically cleaned. For the manual model, there is an alarm indicating when the air flow is too low, and an operating hours meter. The model with automatic cleaning has an advanced filter control system that starts the cleaning process automatically when the airflow is too low. Additional protection from harmful particles given if a HEPA filter is installed.

For dust applications, the unit is cleaned mechanically. For welding fumes it uses a combination of mechanical and compressed air cleaning.

For welding applications, compressed air cleaning is required.

Note: FilterBox is not for use in environments where combustible dust or gases are present, and it is not for use in filtering combustible dust or gases.

FEATURES

- User friendly and superior filter cleaning, mechanical and/or with compressed air for long filter life
- Automatic damper preventing dust from leaking out while cleaning
- Dust free filter replacement and emptying of dust bin
- Third party approval for welding fumes category W3 according to EN 15012-1



NEDERMAN FILTERBOX WALL

DIMENSION DRAWINGS

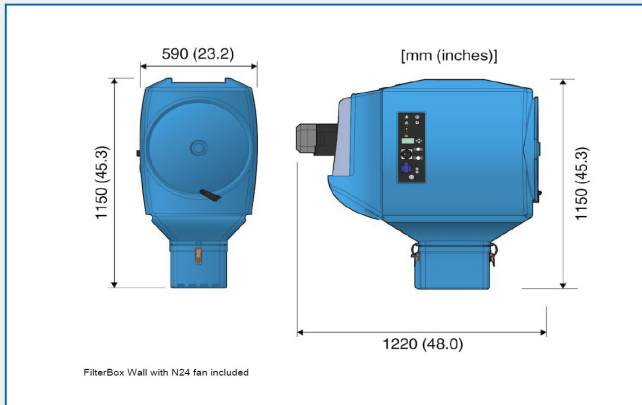

FilterBox with N24

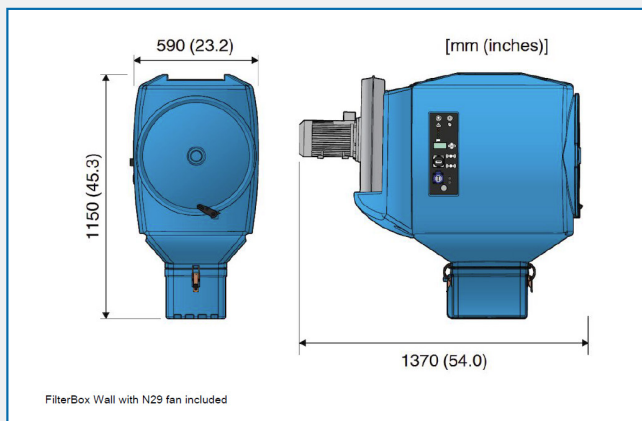

FilterBox with N29

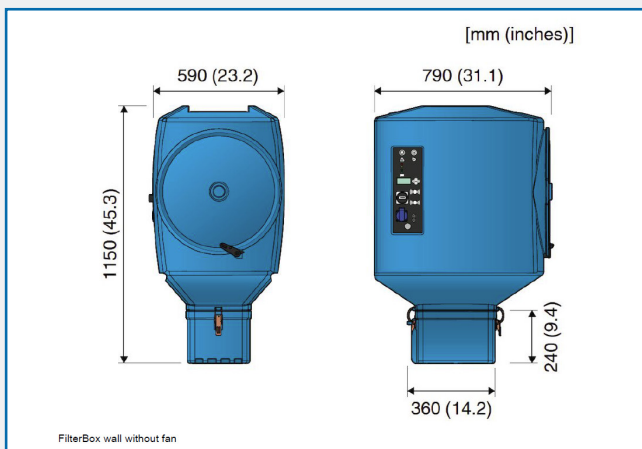

FilterBox without fan

FILTERBOX WALL PART CODES

Power Voltage	Filter Material	No. of Phases	Weight	Part No.
110 V	Polyester PW13	1	54 kg	12682163
230 V	Polyester PW13	1	54 kg	12682063
400 V	Polyester PW13	3	54 kg	12684663
400 V	Polyester PW13	3	54 kg	12684863
400 V	Polyester PW13	3	54 kg	12650263
400 V	Polyester PW13	3	54 kg	12684563
400 V	Polyester PW13	3	54 kg	12650363
400 V	Polyester PW13	3	54 kg	12684763

ACCESSORIES

Accessory	Part No.
Sensor clamp to be attached to the earth cable of the welding power source.	14372199
Bags for FilterBox dust bin, 10 pcs	12376618
Filter PTFE-FB-13	12377252

AES OFFER INSTALLATION AND SERVICE SUPPORT FOR ALL EQUIPMENT