

GEOVENT CERA EXHAUST ARM



DESCRIPTION

The Geovent CERA Exhaust Arm is designed for the removal of vehicle exhaust fumes, and provides a non-contact and efficient extraction.

Mounted on a channel duct, the arm can be moved across or along the workshop.

The arm can be rotated at a 360° angle and adjusted in several joints so that it can be positioned precisely next to the car's exhaust pipe.

CHANNEL DUCT TYPE 25

The Geovent Channel Duct Type 25 is made of aluminium, and is a highly flexible system for the extraction of exhaust fumes. It is designed for large workshops or assembly lines with a linear work flow. The channel duct is also used for the removal of welding fumes.

The trolley can easily be moved between work bays. The system is easy to install, and the channel duct is available with accessories such as electrical wireless forward return of the trolley, compressed air nozzles for automatic dismantling of exhaust pipes, etc.

ADDITIONAL PICTURE



DIMENSIONS

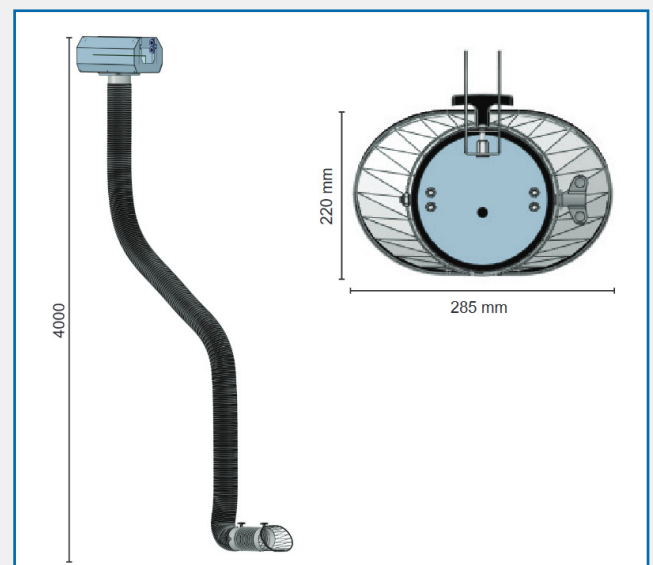

PART CODE/ORDERING TABLE

Part No.	Description
07-470	CERA Exhaust Arm Ø160 mm
07-420	Hose Trolley Type 30
07-400	Channel Duct Type 25

AES OFFER INSTALLATION AND SERVICE SUPPORT FOR ALL EQUIPMENT