

FLEXI EXTRACTION ARM FFK & FVK



Model FFK

DESCRIPTION

The unique Flexi Arm specifically designed for laboratories, hospitals, schools clinics etc aims to remove polluted air at the source and reduce harmful exposure.

Three friction joints and a 360° smooth-turning rotating console allows for smooth operation. The arm then has the ability to be positioned in any desired way to maximise operator safety and efficiency of extraction.

The Flexi arm is supplied as standard in either Ø100 or Ø125 hose and in lengths of 1m or 1.5m. Three mounting configurations are available:

- Wall Mounting Model FVK
- Table Mounting Model FFK
- Ceiling Mounting Model FLK

FLEXI ARMS

Part No.	Description
FLEXI Arm - Ø100 mm	
01-430	FLEXI arm Ø100 0.7 m
01-431	FLEXI arm Ø100 1.0 m
01-432	FLEXI arm Ø100 1.5 m
FLEXI Arm - Ø125 mm	
01-450	FLEXI arm Ø125 0.7 m
01-451	FLEXI arm Ø125 1.0 m
01-452	FLEXI arm Ø125 1.5 m

WALL CEILING OR BENCH MOUNTING

Part No.	Description
01-420	Wall Mounting FLEXI-100
01-421	Bench Mounting FLEXI-100
01-422	Ceiling Mounting FLEXI-100 H= 1000 mm. A= 125 mm
01-423	Ceiling Mounting FLEXI-100 Customised up to 1000 mm
01-424	Ceiling Mounting FLEXI-100 Customised 1000 - 2400 mm
01-440	Wall Mounting FLEXI-125
01-441	Bench Mounting FLEXI-125
01-442	Ceiling Mounting FLEXI-125 H= 1000 mm. A= 138 mm
01-443	Ceiling Mounting FLEXI-125 Customised up to 1000 mm.
01-444	Ceiling Mounting FLEXI-125 Customised 1000 - 2400 mm.

PRESSURE DROP - FLEXI ARM

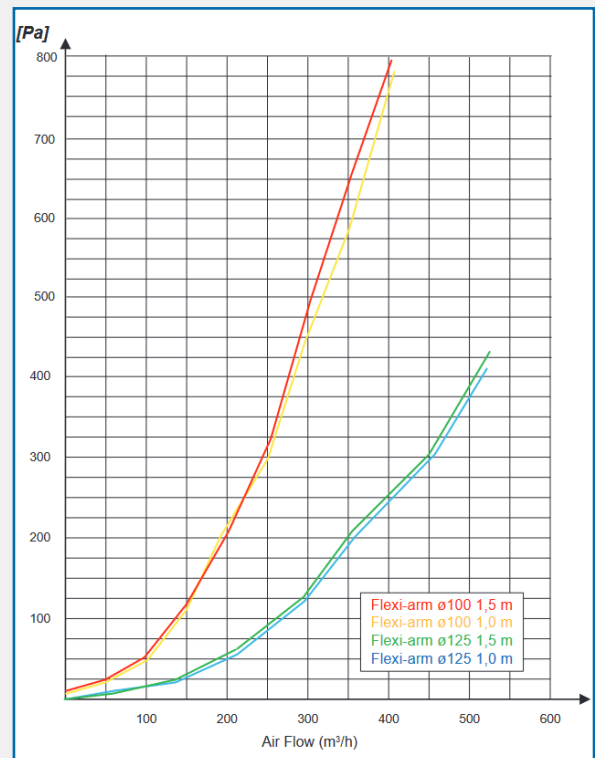

AES OFFER INSTALLATION AND SERVICE SUPPORT FOR ALL EQUIPMENT

FLEXI EXTRACTION ARM FFK & FVK

MOUNTING DIMENSIONS

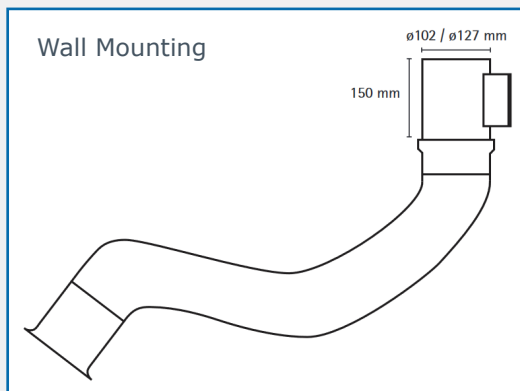
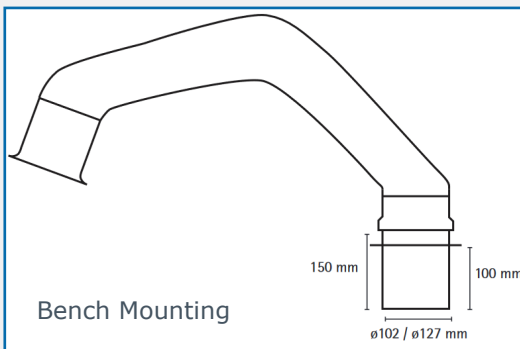
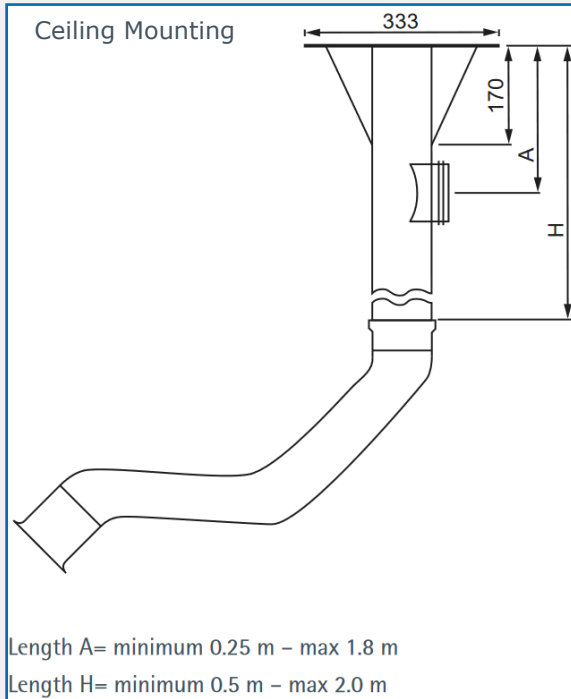

FLEXI ARM DIMENSIONS

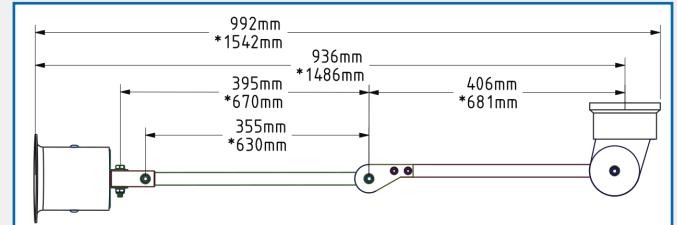

* FLEXI Arm 1.5 m

ARM EXTENSIONS

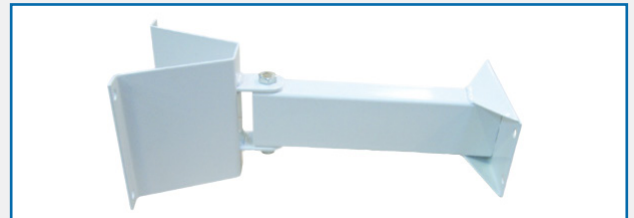

Part No.	Description
01-585	FLEXI FVK Extension 0.5 m
01-586	FLEXI FVK Extension 1.5 m

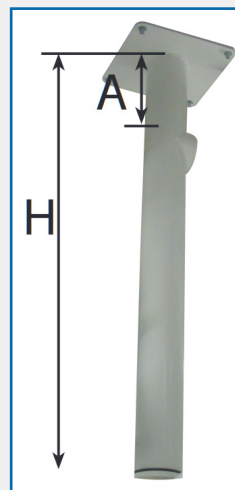

Ceiling Console



Wall Console

AES OFFER INSTALLATION AND SERVICE SUPPORT FOR ALL EQUIPMENT

FLEXI EXTRACTION ARM FFK & FVK

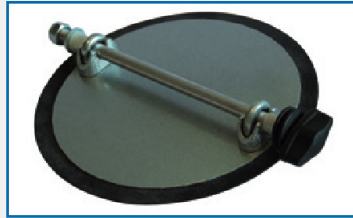

HOODS AND DAMPERS

Part No.	Description
Standard Hood	
01-455	Standard Hood Ø100 mm FLEXI
01-456	Standard Hood Ø125 mm FLEXI
Tight Dampers	
12-006	Tight Damper Ø100 mm for use in hood
12-012	Tight Damper Ø125 mm for use in hood



Part No.	Description
Transparent Polycarbonat hood Ø280 mm	
01-564	Ø100 mm connection
01-567	Ø125 mm connection
Transparent Polycarbonat hood Ø385 mm	
01-566	Ø100 mm connection
01-567	Ø125 mm connection
Transparent Polycarbonat hood Ø500 mm	
01-568	Ø100 mm connection
01-569	Ø125 mm connection



Part No.	Description
Transparent Polycarbonat Hood 265 x 168 mm	
01-558	Ø100 mm connection
01-559	Ø125 mm connection Note: with reduction Ø100 mm



Part No.	Description
Transparent Polycarbonat Hood 330 x 245 mm	
01-556	Ø100 mm connection
01-557	Ø125 mm connection

AES OFFER INSTALLATION AND SERVICE SUPPORT FOR ALL EQUIPMENT