

AES GDB DUST EXTRACTION BENCH



Model shown - GDB15 with optional side mounted silencer

DESCRIPTION

The AES GDB recirculating downdraft benches are suitable for the capture of dust generated by **non-sparking** applications.

These benches are available in four lengths and supplied with G4 panel pre-filter + main HEPA H13 pocket filter.

The filters are front loading and can be changed by the end user without the need to move the bench when filter change or maintenance is required.

FEATURES

- Dust collection drawer
- Rear panel with extraction and side panels (removable) to maximise the bench efficiency
- Extraction fan 400V 3 Phase as standard
- GDB-10/15 can be supplied 240v single phase.
- Two stage filtration.
- Multifunction LCD display
- Additional options include a side mounted silencer and enclosure.

TECHNICAL SPECIFICATION

	GDB 10	GDB 15	GDB 20	GDB 30
Dimensions (AxBxH) (mm)	1210 x 900 x 1400	1710 x 900 x 1400	2210 x 900 x 1400	3100 x 900 x 1400
Extraction Desk (axbxh) (mm)	870 x 715 x 960	1370 x 715 x 960	1870 x 715 x 960	2760 x 715 x 960
Outlet Dimensions (cx d) (mm)	415 x 200	415 x 200	415 x 200	415 x 200
Maximum Load (Kg/m ²)	150	150	150	150
Airflow (m ³ /h)	2250	3000	4500	4800
Power (kW)	1.1	1.5	2.2	2.2
Pressure (Pa)	600	600	600	600
Filter Surface (m ²)	18	18	36	54
G4-FILPMK23SP0592X0592-00	Qty 1	Qty 1	Qty 2	Qty 3
HEPA-TASH3R292H0592X0592-00	Qty 1	Qty 1	Qty 2	Qty 3
Sound Level dB(A)	73	78	74	78

Optional side mounted silencer adds approx 500mm to width (A) and 600mm to height (H) of bench

DIMENSIONS DRAWING

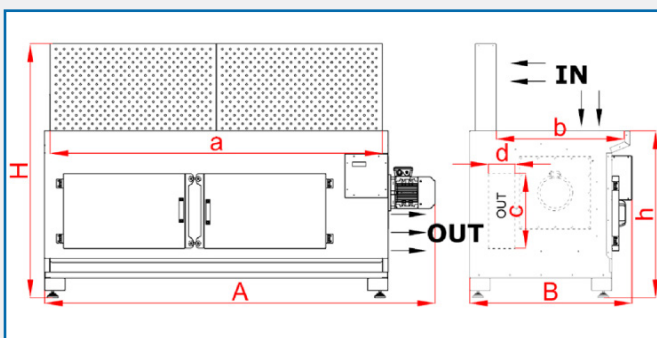

AIRFLOW PATH

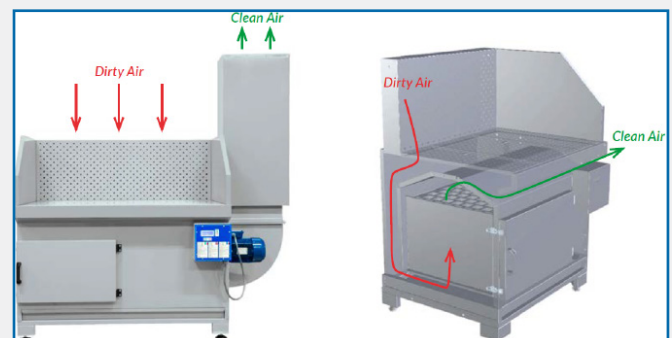

AES OFFER INSTALLATION AND SERVICE SUPPORT FOR ALL EQUIPMENT

AES GDB DUST EXTRACTION BENCH



GDB10 with optional side mounted silencer (-10dB).

MULTIFUNCTION DISPLAY



A multifunction display is included as standard with all benches in GPB range. The display includes pressure gauge and hour counter to know at any time when maintenance or filter replacement are necessary.

OPTIONAL ACCESSORIES

- Side mounted silencer to reduce noise level by up to -10dB
- Heavy duty castors
- Enclosure with / without LED light
- Upgraded surface load bearing to 250kg/m²
- Vice preparation plate
- Desk mounted plastic strips
- 350 mm knee space extension
- RAL colour can be specified
- Spare filter kit



Model shown - GDB15

Front loading maintenance access for filter change.

AES GDB BENCH - APPLICATION GUIDE

NO SPARKING DUST	VERY FINE DUST
Aluminium	Fingerprintings
Plastics	Rapidprototyping
Atmospheric dusts	Model making
Flour or similar	Conservation & restoration
GRP	Printer/copier toner cartridge recycling
	Powder sampling
FINE DUSTS	HEPA
Carbon fibre finishing/sanding	Pharmaceuticals
Powder sampling	Hardwoods and MDF
Other composites	Laboratory/Optical
Softwood dusts	Materials containing RCS
Airline cleaning	Hazardous dusts
Suitable for most general dust applications	
FILTERS	<i>Models available</i>
G4 PANEL FILTER	GDB10-G4-H13 - 1.0 m
H13 Pocket Filter	GDB15-G4-H13 - 1.5 m
Final Filter Efficiency	GDB20-G4-H13 - 2.0 m
99.95% Minimum efficiency (0.3 micron)	GDB30-G4-H13 - 3.0 m



GDB-15 with optional side mounted silencer and enclosure with LED light.

AES OFFER INSTALLATION AND SERVICE SUPPORT FOR ALL EQUIPMENT