

## GEOVENT CENTRIFUGAL FAN MEF 355

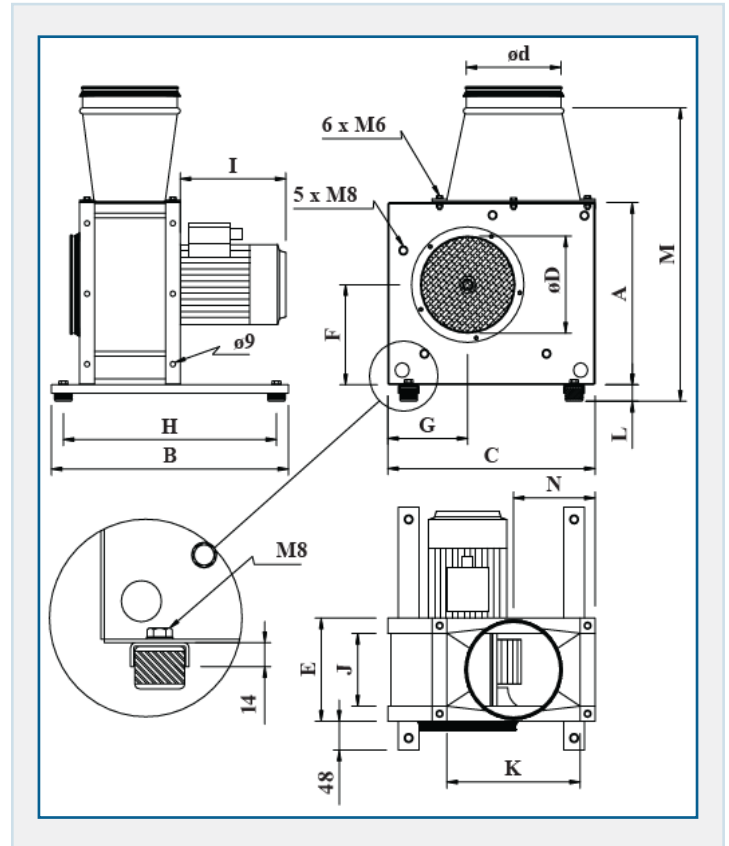

### DESCRIPTION

The Geovent MEF centrifugal fan with closed backward curving B-wheel and directly driven flange motor is suitable for continuous extraction within industry. Applications include the extraction of welding smoke, exhaust gases, grinding dust and vapours.

Produced in sizes with Airflow up to 24000 m<sup>3</sup>/h – Pressure up to 4500 Pa. The fan has a high efficiency and is suitable for PID/constant pressure regulation.

The fan is made 100% galvanized steel for optimum corrosion resistance and therefore it is suitable for outdoor roof or wall installation.

As standard we supply supporting bracket with vibration absorbers, inlet nozzle with net and clamp for mounting the required outlet flange.

Also available, LEF fans typically used for general ventilation as well as for smaller process extraction jobs where a high pressure is not required and LEX / MEX ATEX versions

Dimension Table for MEF Fans (mm)

Type	355
A	570
B	655
C	680
D	400
E	*
F	284
G	329
H	272
I	460
J	*
K	234
L	450
M	797
N	250
Weight	48kg*

\*depends on motor choice

AES OFFER INSTALLATION AND SERVICE SUPPORT FOR ALL EQUIPMENT

# GEOVENT CENTRIFUGAL FAN MEF 355

## PRESSURE LOSS

Dust amounts and corn size. The dust amount from the extracted air may not exceed 12 g/m<sup>3</sup>. The size of the dust particles may not exceed 6 mm<sup>3</sup>. The dust/steams may not be sticky.

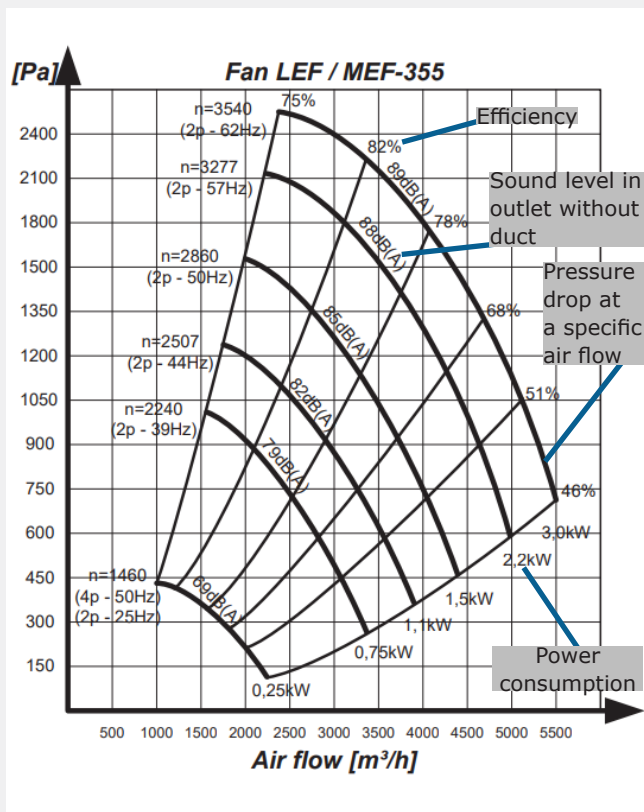

## ACCESSORIES

Complete range of accessories, including options, such as flex connection, mountings, rain shield, motor protection, pressure monitor and soundproof box.

**Soundproof box** for sound level reduction. The fan is enclosed in a wind and waterproof galvanised box. The sound is typically subdued to 8-15 dB(A)



**Outlet flange**, in hot-galvanised steel. Supplied in several different sizes, used to transition from the fan's square yield.



## TECHNICAL SPECIFICATION

Motor	Directly driven by a B5
Flange Motor	Sealing Class IP-55
Voltage	3x400V or 1x230V / 50Hz
Airflow (MSFG)	See fan curve overleaf
Pressure (MSFG)	See fan curve overleaf

AES OFFER INSTALLATION AND SERVICE SUPPORT FOR ALL EQUIPMENT

## GEOVENT CENTRIFUGAL FAN MEF 355

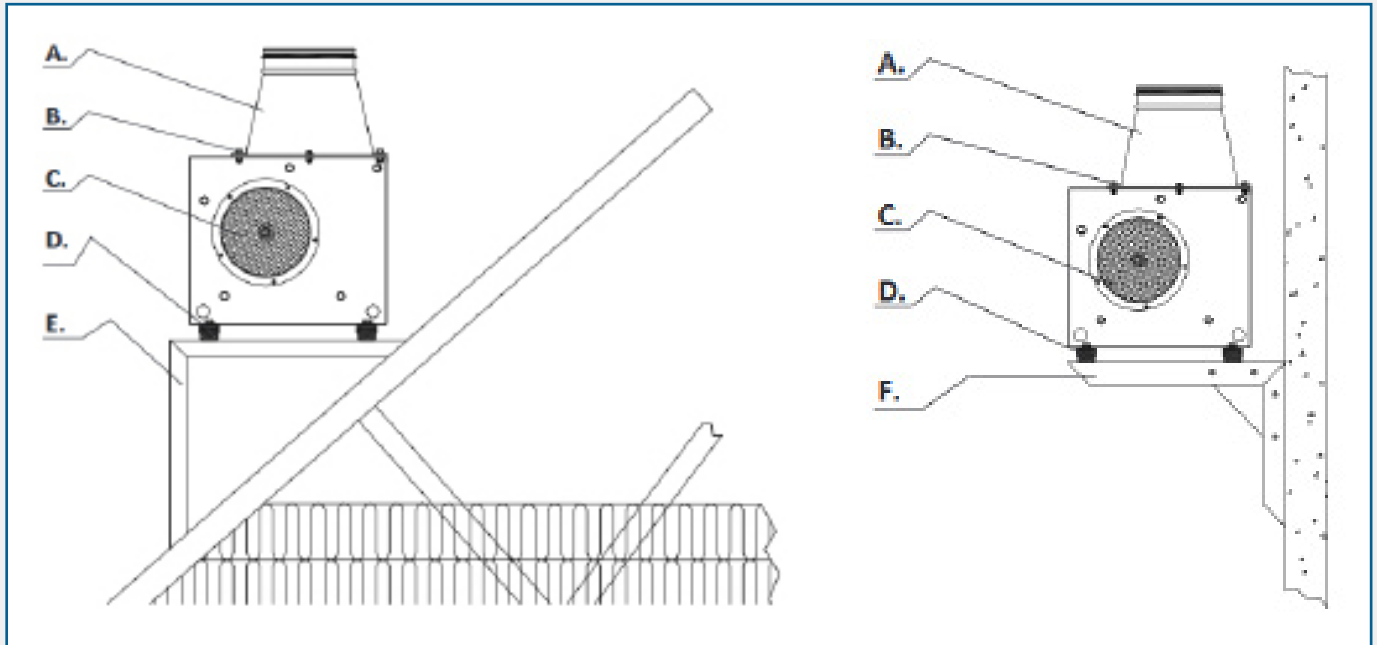

### MOUNTING CONFIGURATIONS

**A** - Outlet flange  
**B** - Clamp  
**C** - Inlet in sleeve

**D** - Supporting Angles  
**E** - Roof Bracket GB15°-45°  
**F** - Wall Bracket

### PART CODES

Part. Number	Model	Power (kW)	Current (A)
34-702	MEF-355-3*	0.75	1.9
34-703	MEF-355-3*	1.1	2.4
34-704	MEF-355-3	1.5	3.15
34-705	MEF-355-3*	2.2	4.4
34-706	MEF-355-3*	3	5.75
34-707	MEF-355-1	1.5	8.75

\*Requires the use of an external frequency inverter.

### SOUND DATA - MEASURED AT INLET

Type	125 Hz	250 Hz	500 Hz	1000 Hz	2000 Hz	4000 Hz	8000 Hz	Lp, dB (A)	Lp, 1m
MEF 355	95.7	81.8	77.5	78.0	76.2	68.4	66	84.7	96.1

AES OFFER INSTALLATION AND SERVICE SUPPORT FOR ALL EQUIPMENT