

VEHICLE EXHAUST CHANNEL DUCT TYPE 25

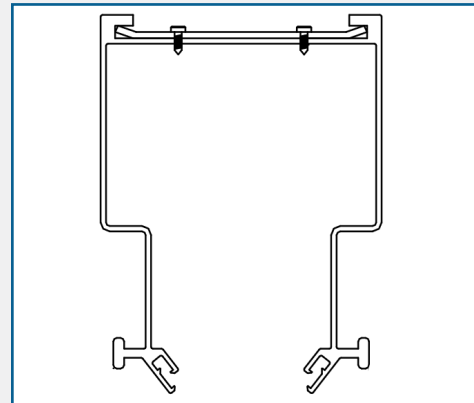

CROSS SECTION OF CHANNEL DUCT



TECHNICAL SPECIFICATION

Dimensions	600 x 200 x 280 mm
Weight (Duct Only)	9 kg/m
Capacity	1200 m ³ /h
Rail	<ul style="list-style-type: none"> • Extruded Aluminium • Neoprene rubber lips • 5/600 Pa Vacuum • Self Sealing
Trolley	Powdered Enameled Steel 6 smooth running Nylon wheels
Balancer	Variable as per system, safeguards hose retraction and floor distance.
Hose	TPE degas-hose with nylon spiral. Alternatively, a silicone high-temperature hose for high-temperature fumes.
Nozzle	To be fixed to the exhaust pipe of vehicle, not included with channel duct or trolley.
Temperatures	Up to 150°C Surroundings: 0 - 50°C

DESCRIPTION

Constructed from extruded aluminium and in lengths up to 48m, the channel duct can cover a large working area. The channel duct can be fitted with up to 6 trolleys allowing extraction hoses to be fitted to each. The duct follows a linear flow pattern and is ideal for medium/large vehicle workshops. The channel duct is also capable of carrying hose reels and extraction arms.

AES can supply channel duct configurations for all vehicle exhaust design specifications, to be fitted with trolleys, hose reels, extraction arms or a combination of these.

OPERATION

The hose trolley is equipped with 6 smoothly rolling nylon wheels. The movement of the trolley requires minimum effort, and the floor space is increased by having the channel duct mounted along the ceiling or wall. There are a vast amount of accessories available for the channel duct, facilitating any type of work for the operator.

AES PART CODE/ORDERING TABLE

Channel Duct Type 25, Extruded Aluminium with heat resistant neoprene rubber lips	DF-CD01-001
Channel Duct Type 25 Trolley with 6 smooth running nylon wheels	DF-CD01-002

AES OFFER INSTALLATION AND SERVICE SUPPORT FOR ALL EQUIPMENT

VEHICLE EXHAUST CHANNEL DUCT TYPE 25

PRESSURE DROP GRAPH - CHANNEL DUCT LENGTHS

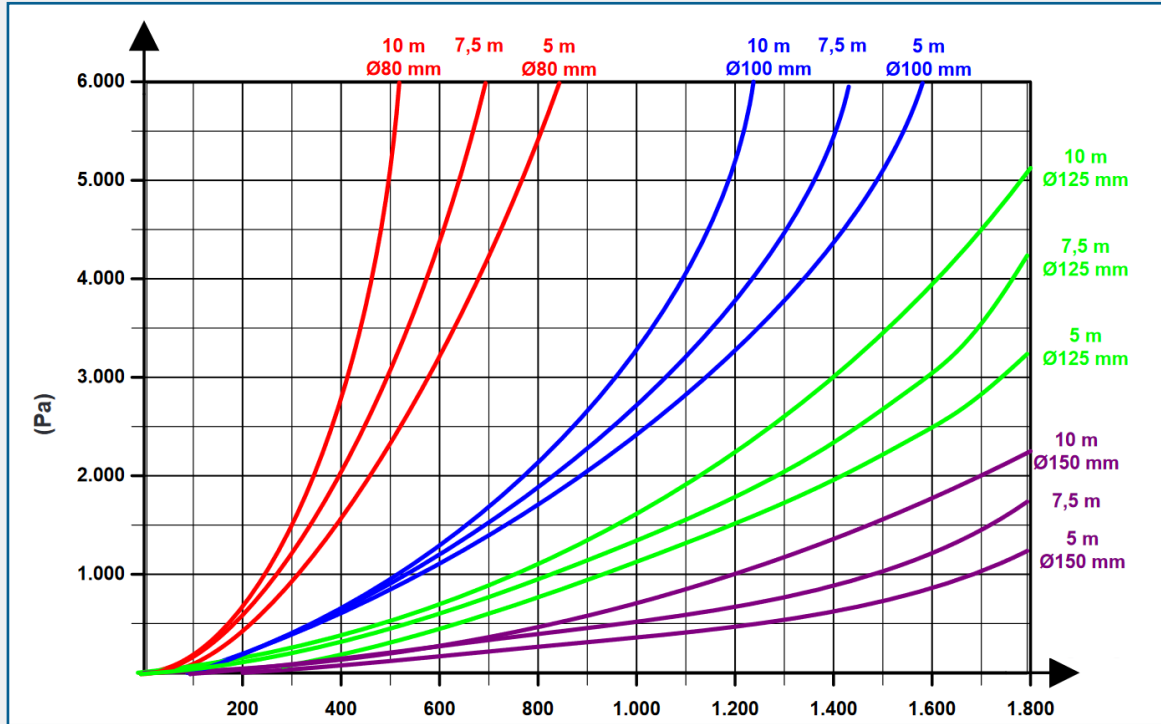

PRESSURE - CHANNEL DUCT TYPE 25

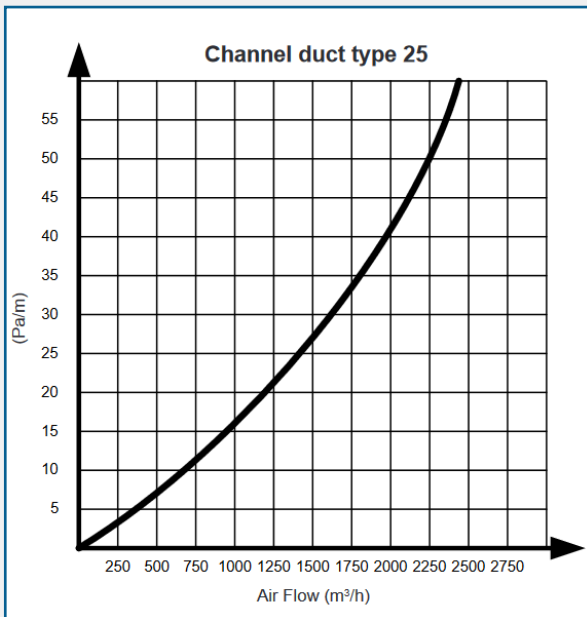

PRESSURE - CHANNEL DUCT WITHOUT HOSE

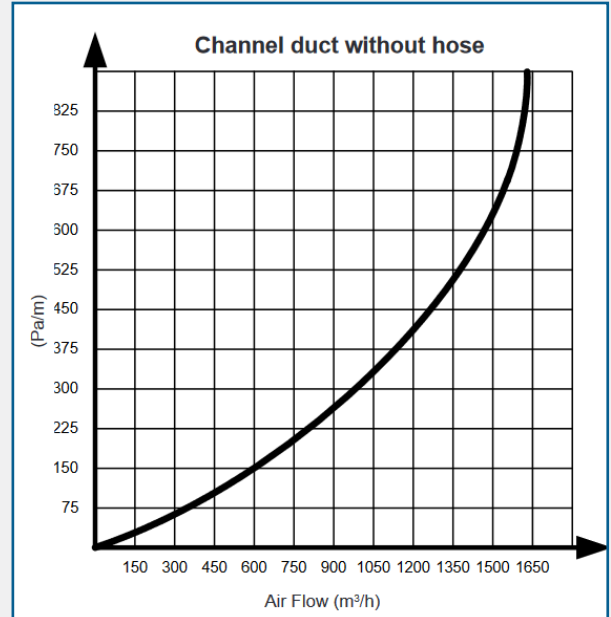

AES OFFER INSTALLATION AND SERVICE SUPPORT FOR ALL EQUIPMENT

VEHICLE EXHAUST CHANNEL DUCT TYPE 25

CHANNEL DUCT VARIOUS OPTIONS - DIAGRAM

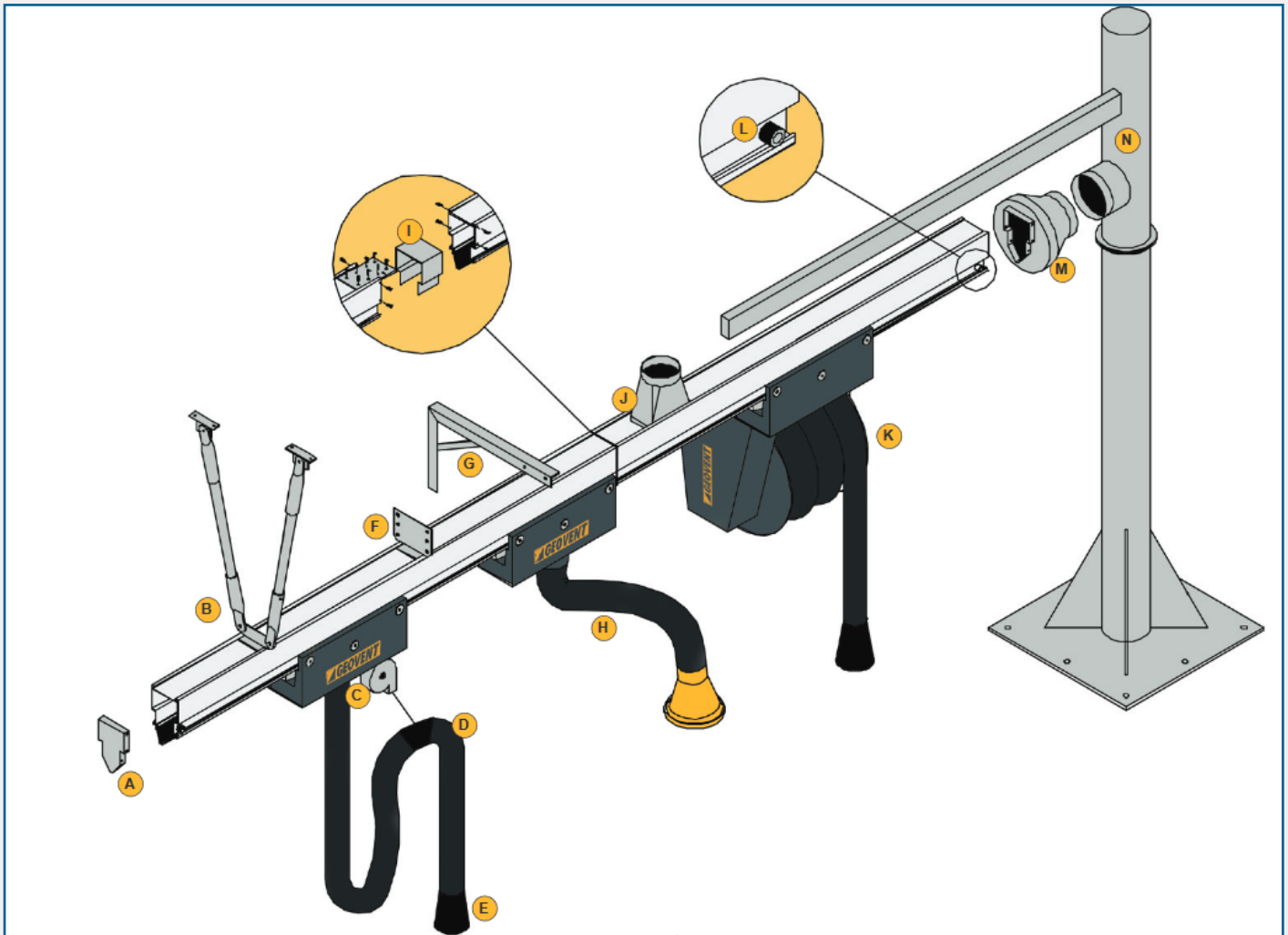

KEY

- A:** End cover
- B:** Ceiling bracket
- C:** Balancer
- D:** Hose mount LWS
- E:** Rubber Nozzle
- F:** Suspension Bracket type 160
- G:** Wall mount
- H:** Extraction Arm (WING/COMPACT)
- I:** Connection
- J:** Outlet Flange, top
- K:** Hose Reel with Nozzle
- L:** End stop
- M:** Channel reduction, end
- N:** Pivotable arm 180° or 360°

TROLLEY 2000M

8 wheels and Ø250mm NP connection
(L=1000mm, W=200mm, H=289mm)
for Airflows up to 2,000m³/h

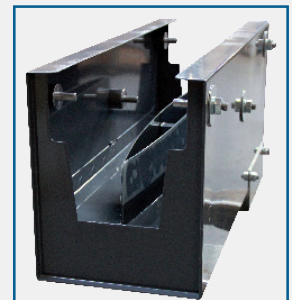

AES OFFER INSTALLATION AND SERVICE SUPPORT FOR ALL EQUIPMENT