

GEOVENT GEOFILTER OIL 100 & 160

SET UP EXAMPLE

It is advised to use an oil separator with each machine. In connection with the oil separator, you can use the Mini Arm or ASA arm as shown in the figure below.

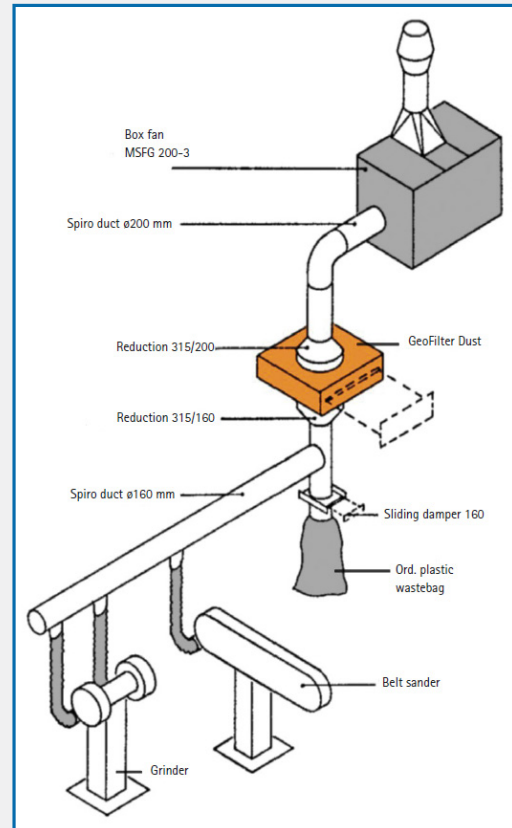

DESCRIPTION

The Geovent GeoFilter Oil used from the removal of oil mist from the cutting machines before it reaches the central piping system.

This avoids the oil condenses in the pipeline. The GeoFilter Oil is available in 2 sizes: 100 & 160. The size refers to the diameter of the outlet.

- Size 100 mainly used with conventional lathes, milling machines, wet grinders, etc.
- Size 160 primarily used in connection with CNC machining centers and lathes.

Item No:

- Geo Filter Oil 100 - 15-020
- Geo Filter Oil 160 - 15-220

DIMENSIONS DRAWING

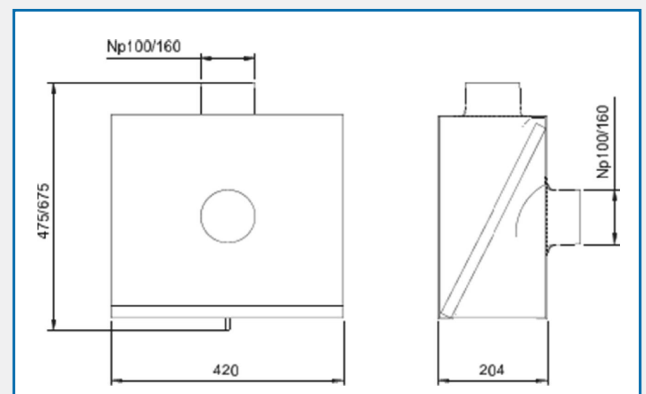

AES OFFER INSTALLATION AND SERVICE SUPPORT FOR ALL EQUIPMENT

GEOVENT GEOFILTER OIL 100 & 160

ACCESSORIES

The filter media, which is made of aluminium mat is detachable via the removable bottom.

The GeoFilter is equipped with a tap for the captured oil, which returns to the machine.

The oil separator is manufactured in epoxy-enameled steel.

Filter area, size 100: 0.13 m²

Filter area, size 160: 0.19 m²

Accessories

15-030 Replacement filter 100 400x400

15-031 Replacement filter 160 400x600

ADDITIONAL PICTURE



PRESSURE DROP DIAGRAM

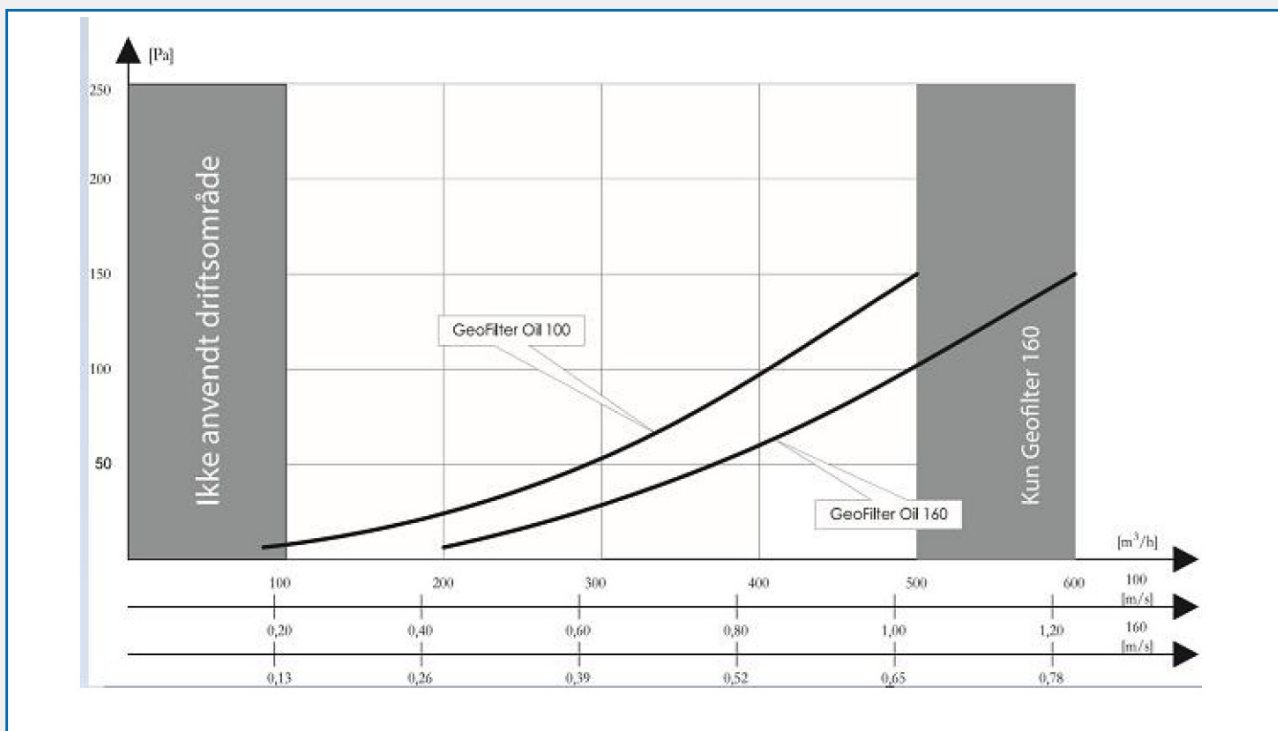

AES OFFER INSTALLATION AND SERVICE SUPPORT FOR ALL EQUIPMENT