

## NEDERMAN FAN N 24 - SINGLE PHASE



### TECHNICAL SPECIFICATION

Installation	(Indoor), (Outdoor)
Material	Fan casings: Galvanised sheet Steel Impeller: Die cast aluminium
Airflow	1500 m <sup>3</sup> /h
Capacity (Max. Airflow)	1500 m <sup>3</sup> /h
Ambient temperature range	-20 to +40 C
Operating temperature	Max. 60 C
Power Voltage	115/230 V
Frequency	50 Hz
No. of phases	1
Amperage	13.6/6.5 A
Weight	17 kg
Power	0.75 kW
Sound Level	61 dB(A) at 1200 m <sup>3</sup> /h

### DESCRIPTION

Nederman Fan N24 is a centrifugal fan designed for use with extraction products. The fan can also be mounted on a stand which is available as an accessory.

### DIMENSIONS DRAWING

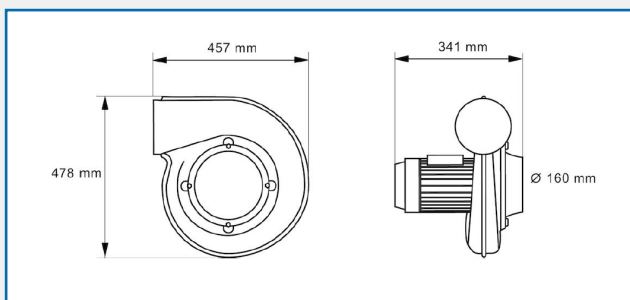

### PRESSURE DROP GRAPH

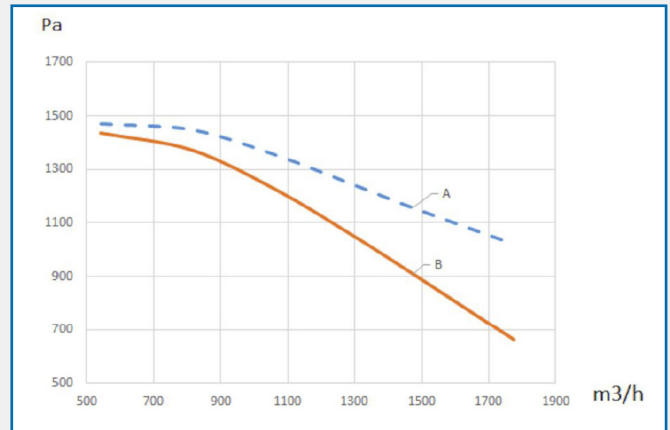

A = Fan total pressure  
B = Fan static pressure

### PART CODES

Description	Voltage	Power	Part Code
N24 Fan - Single Phase	115 V 230 V	0.75 kW	14510122

AES OFFER INSTALLATION AND SERVICE SUPPORT FOR ALL EQUIPMENT

## NEDERMAN FAN N 24 - SINGLE PHASE

### ACCESSORIES

FMS 6.3 - 10	14502537
FMS 10 - 16	14502637
Manual fan control. 3.2 - 11.3 A, 1 ph.	14518937
Automatic fan control. 3.2 - 11.3 A, 1 ph.	14519337*
Adaptor Ø125/Ø100 mm	14341077
Adaptor Ø125/Ø75 mm	14341080
Adaptor Ø160/ext. Ø75 mm	14510426
Adaptor Ø160/ext. Ø100 mm	14510526
Adaptor Ø160 ext. /Ø100 mm	14510626
Adaptor Ø160/Ø100 mm	14511226
Inlet adaptor for hose Ø160 mm	14510326
Inlet and outlet adaptor for hose Ø160 mm	14322166
Guard net (1 pcs)	14333181
PVC hose. Ø100 mm. l=5m	10500427
PVC-hose. Ø125 mm. l=5m	10500527
PVC-hose. Ø150 mm. l=5m	10500627
PVC-hose. Ø160 mm. l=5m	10511026
Coupling tube Ø75mm	14503626
Coupling tube Ø100mm	14504626
Coupling tube Ø125mm	14505626
Coupling tube Ø150mm	14506626
Coupling tube Ø160mm	14511326
Nozzle with magnet. 250 x 30 mm. Aluminium. Hose connection Ø100 mm.	14500226
Nozzle with magnet. 260 x 100 mm. Polycarbonate. Hose connection Ø100 mm.	14501226
Silencer for when mounted on Original or Telescopic extraction arm	14502126
Silencer for fan	14502626
Silencer including quick release	14502226
Wall bracket for silencer	14343089
Split inlet Ø125 int. / 2xØ100 mm ext.	14500526
Split inlet Ø125 int. / 2xØ100 mm ext.	14500726
Split inlet Ø160 int. / 2xØ100 mm ext.	14510726
Split inlet Ø125 int. / 2xØ100 mm ext.	14500826
Support bracket for N10/N16/N24/N27 for fixed mounting. Incl guard net and inlet connection.	14510126
Support bracket for portable N16 and N24 fan	14511426

AES OFFER INSTALLATION AND SERVICE SUPPORT FOR ALL EQUIPMENT